

ARMY TM 11-5411-211-24P  
NAVY EE996-AA-PLL-010/E1 54 S639  
AIR FORCE TO 35E4-172-4-1

---

TECHNICAL MANUAL

ORGANIZATIONAL, DIRECT SUPPORT, AND GENERAL  
SUPPORT MAINTENANCE REPAIR PARTS AND  
SPECIAL TOOLS LISTS

FOR

SHELTER, ELECTRONIC EQUIPMENT  
MAINTENANCE S-6391G  
(NSN 5411-01-127-6853)

---

DEPARTMENTS OF THE ARMY, THE NAVY, AND THE AIR FORCE  
7 FEBRUARY 1985

Technical Manual  
No 11-5411-211-24P  
Technical Manual  
EE996-AA-PLL-010/E154 S639  
Technical Order  
No. 35E4-172-4-1

DEPARTMENTS OF THE ARMY,  
THE NAVY, AND THE AIR FORCE

Washington, DC, 7 February 1985

ORGANIZATIONAL, DIRECT SUPPORT, AND GENERAL SUPPORT MAINTENANCE  
REPAIR PARTS AND SPECIAL TOOLS LISTS

FOR

**SHELTER, ELECTRONIC EQUIPMENT MAINTENANCE S-6391G  
(NSN 5411-01-127-6853)**

Current as of 25 January 1985

**REPORTING ERRORS AND RECOMMENDING IMPROVEMENTS**

You can help improve this manual if you find any mistakes or if you know of a way to improve the procedures, please let us know. Mail your letter, DA Form 2028 (Recommended Changes to Publications and Blank Forms), or DA Form 2028-2 located in back of this manual direct to Commander, US Army Communications-Electronics Command and Fort Monmouth, ATTN AMSEL-ME-MP, Fort Monmouth, New Jersey 07703-5007.

For Air Force, submit AFTO Form 22 (Technical Order System Publication Improvement Report and Reply) in accordance with paragraph 6-5, Section VI, T O 00-5-1 Forward direct to prime ALC/MST.

For Navy, mail comments to the Commander, Naval Electronics Systems Command, ATTN ELEX 8122, Washington, DC 20360.

In either case, a reply will be furnished direct to you.

**TABLE OF CONTENTS**

	Page	Illus Figure
Section I. Introduction.....	1	
II. Repair Parts List.....	5	
Group 00 Shelter, Electronic Equipment Maintenance S-6391G.....	5	1
01 Bracket Installation		
Bracket Installation (Roadside and Front Wall).....	11	2
Bracket Installation (Curbside and Rear Wall).....	17	3
0101 Utilities Installation, Electrical.....	23	4
010101 Raceway Installation		
Raceway Installation (Roadside and Rear Wall).....	27	5
Raceway Installation (Curbside, Front Wall and Ceiling).....	31	6
01010101 Shelter S-280/G, Modified (See TM 11-5410-213-15P and TB 750-240 for parts)		
01010102 Power Entrance Box (208V-30).....	35	7

\*This manual supersedes TM 11-5411-211-24P, 23 July 1984

TABLE OF CONTENTS (CONT)

		Page	Illus Figure
Group	01010103 Power Distribution Box (208V-30).....	39	8
	01010104 Main Line Power Filter Box . . . . .	41	9
	01010105 Air Conditioner, 9000 BTU (See TM 5-1420-239-34P for parts)		
02	Telephone TA-312/PT (See TM 11-5805-201-34P for parts)		
03	Heater.....	45	10
04	Intercom LS-147F/F1 (See TM 11-5830-256-23P for parts)		
05	Power Supply, DC PP-4763A/GRC (See TM 11-5820-765-34P-1 for parts)		
06	Power Cables.....	49	11
Section III.	Special Tools List (Not Applicable)		
IV.	National Stock Number and Part Number Index.....	51	

**SECTION I.**

**INTRODUCTION**

**1. Scope**

This manual lists spares and repair parts, special tools, special test, measurement, and diagnostic equipment (TMDE), and other special support equipment required for performance of organizational, direct support, and general support maintenance of the (Shelter, Electronic Equipment Maintenance S-639/G) It authorizes requisitioning and issue of spares and repair parts as Indicated by the source and maintenance codes.

**2. General**

This Repair Parts and Special Tools List is divided into the following sections

a. Section II Repair Parts List A list of spares and repair parts authorized for use in the performance of maintenance The list also includes parts which must be removed for replacement of the authorized parts Parts lists are composed of functional groups in numeric sequence, with the parts in each group listed in figure and Item number sequence

b Section 111. Special Tools List Not applicable.

c. Section IV National Stock Number and Part Number Index A list, in National item Identification number (NIIN) sequence, of all National stock numbers (NSN) appearing in the listings, followed by a list, in alphameric sequence, of all part numbers appearing in the listings National stock numbers and part numbers are cross-referenced to each illustration figure and item number appearance

**3. Explanation of Columns**

a Illustration. This column is divided as follows

(1) Figure number Indicates the figure number of the Illustration on which the item is shown

(2) Item number The number used to identify Item called out in the Illustration.

b Source, Maintenance, and Recoverability (SMR) Codes.

(1) Source code Source codes indicate the manner of acquiring support Items for maintenance, repair, or overhaul of end Items Source codes are entered in the first and second positions of the Uniform SMR Code format as follows

Code	Definition
PA -	Item procured and stocked for anticipated or known usage
XB -	Item is not procured or stocked If not available through salvage, requisition
XC -	Installation Drawing, Diagram, Instruction Sheet, Field Service Drawing, that Is Identified by Manufacturer's Part Number

**NOTE**

Cannibalization or salvage may be used as a source of supply for any Items source coded above except those coded XA and aircraft support Items as restricted by AR 700-42

(2) Maintenance code Maintenance codes are assigned to indicate the levels of maintenance authorized to USE and REPAIR support Items The maintenance codes are entered in the third and fourth positions of the Uniform SMR Code format as follows

(a) The maintenance code entered in the third position will indicate the lowest maintenance level authorized to remove, replace, and use the support Item The maintenance code entered In the third position will indicate one of the following levels of maintenance

Code	Application/Explanation
O-	Support Item is removed, replaced, used at the organizational level

F -Support item is removed, replaced, used at the direct support level

(b) The maintenance code entered in the fourth position indicates whether the item is to be repaired and identifies the lowest maintenance level with the capability to perform complete repair (i.e, all authorized maintenance functions) This position will contain one of the following maintenance codes:

Code	Application/Explanation
O -	The lowest maintenance level capable of complete repair of the support item is the organizational level.
F -	The lowest maintenance level capable of complete repair of the support item is the direct support level
D	The lowest maintenance level capable of complete repair of the support item is the depot level
Z	Nonreparable No repair is authorized (3)

Recoverability code Recoverability codes are assigned to support items to indicate the disposition action on unserviceable items. The recoverability code is entered in the fifth position of the Uniform SMR Code format as follows:

Recoverability Code	Definition
Z-	Nonreparable item. When unserviceable, condemn and dispose at the level indicated in position 3
O-	Reparable item When uneconomically reparable, condemn and dispose at the organizational level.
F-	Reparable item. When uneconomically reparable condemn and dispose at the direct support level
D-	Reparable item. When beyond lower level repair capability, return to depot. Condemnation and disposal not authorized below depot level

c National Stock Number. Indicates the National stock number assigned to the item and will be used for requisitioning purposes

d. Federal Supply Code for Manufacturer (FSCM) The FSCM is a 5-digit numeric code listed in SB 708-41/42 which is used to identify the

manufacturer, distributor, or Government agency, etc  
 e. Part Number Indicates the primary number used by the manufacturer (individual, company, firm, corporation, or Government activity), which controls the design and characteristics of the item by means of its engineering drawings, specifications, standards, and inspection requirements to identify an item or range of items

**NOTE**

When a stock numbered item is requisitioned, the repair part received may have a different part number than the part being replaced

f. Description. Indicates the Federal item name and, if required, a minimum description to identify the item In the Special Tools List, the initial basis of issue (BOI) appears as the last line in the entry for each special tool, special TMDE, and other special support equipment When density of equipments supported exceeds density spread indicated in the basis of issue, the total authorization is increased accordingly

g. Unit of Measure (U/M) Indicates the standard of the basic quantity of the listed item as used in performing the actual maintenance function This measure is expressed by a two character alphabetical abbreviation (e.g, ea, in, pr, etc) When the unit of measure differs from the unit of issue, the lowest unit of issue that will satisfy the required units of measure will be requisitioned.

h. Quantity Incorporated in Unit Indicates the quantity of the item used in the breakout shown on the illustration figure, which is prepared for a functional group, subfunctional group, or an assembly. A "V" appearing in this column in lieu of a quantity indicates that no specific quantity is applicable (e g, shims, spacers, etc)

4. Special Information

a The following publications pertain to the Shelter, Electronic Equipment Maintenance S-639/G and its components

- TM 11-5830-221 12, Intercommunication Stations LS-147A/F1, LS-147B/F1, LS-147C/F1, and LS-147D/F1
- TM 11-5830-256-23P, Intercommunication Station LS-147F/F1

TM 11-5805-201-34P, Telephone Set TA-3121PT

TM 11-5410-213-14P-1, Shelter, Electrical Equipment S-2801G

TB43-0124, Shelter, Electrical Equipment S-280C/G

TM 5-4120-239-34P, Air Conditioners

TM 11-5411-211-14, TO 35E4-172-1, EE996-AA-OMI-010/E154 S639, S640, Shelter, Electronic Equipment Maintenance

b National stock numbers (NSN's) that are missing from P source coded items have been applied for and will be added to this TM by future change/revision when they are entered in the Army Master Data File (AMDF) Until the NSN's are established and published, submit exception requisitions to Commander, US Army Communications-Electronics Command and Fort Monmouth, ATTN AMSEL-MM, Fort Monmouth, NJ 07703-5006 for the part required to support your equipment.

## 5. How to Locate Repair Parts

a When National stock number or part number is unknown

(1) First Using the table of contents, determine the functional group within which the Item belongs This is necessary since illustrations are prepared for functional groups and listings and divided into the same groups

(2) Second Find the Illustration covering the functional group to which the Item belongs

(3) Third Identify the item on the illustration and note the illustration figure and Item number of the Item

(4) Fourth Using the Repair Parts Listing, find the figure and Item number noted on the illustration

b When National stock number or part number is known

(1) First Using the Index of National Stock Numbers and Part Numbers, find the pertinent National stock number or part number This index is in NIIN sequence followed by a list of part numbers In alphanumeric sequence, crossreferenced to the Illustration figure number and item number

(2) Second After finding the figure and Item number, locate the figure and item number in the repair parts list

## 6. Abbreviations

Not applicable

REPAIR PARTS LIST

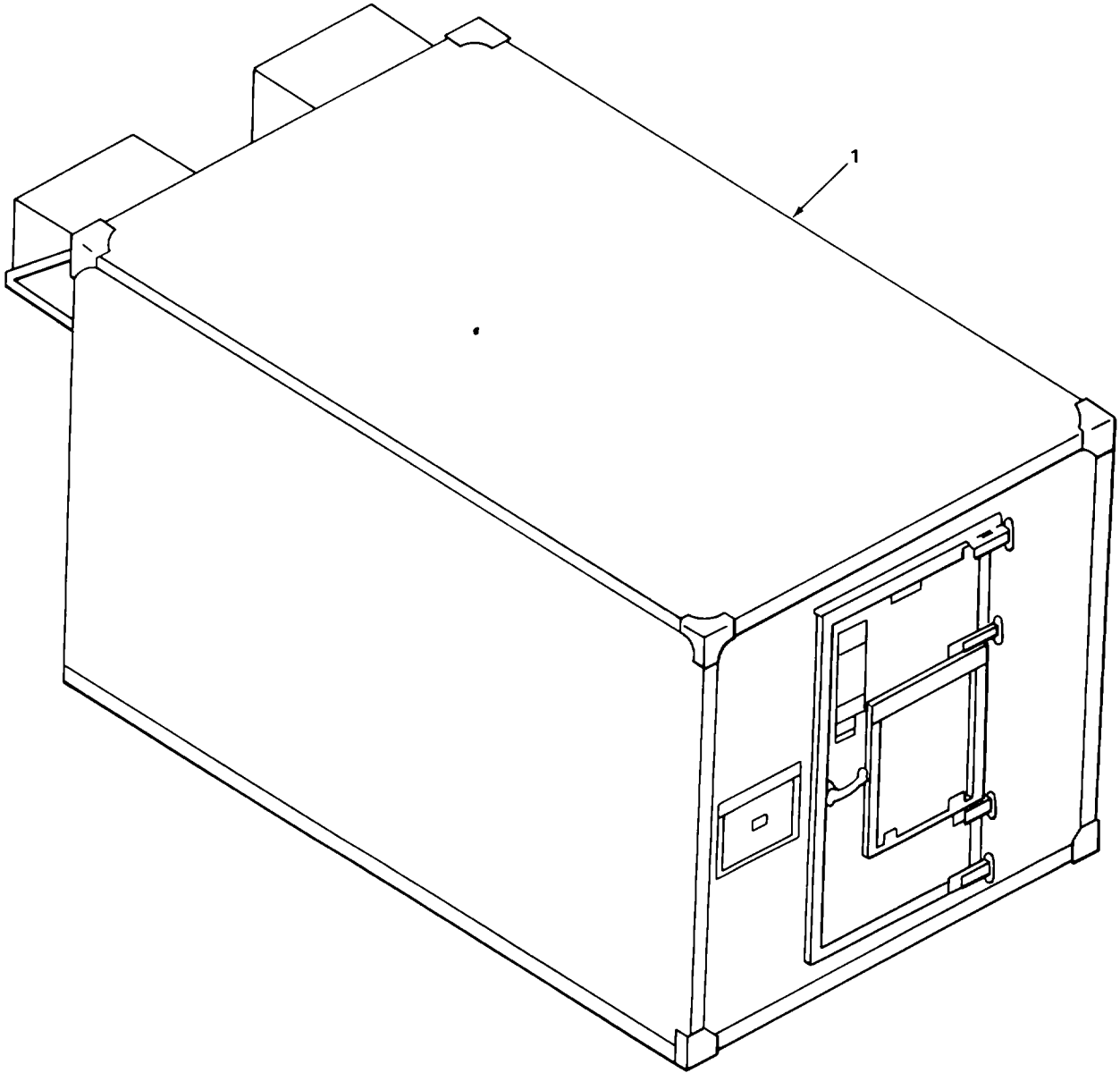

EL8YY039

FIGURE 1. SHELTER, ELECTRONIC EQUIPMENT MAINTENANCE S-639/G (SHEET 1 OF 4)

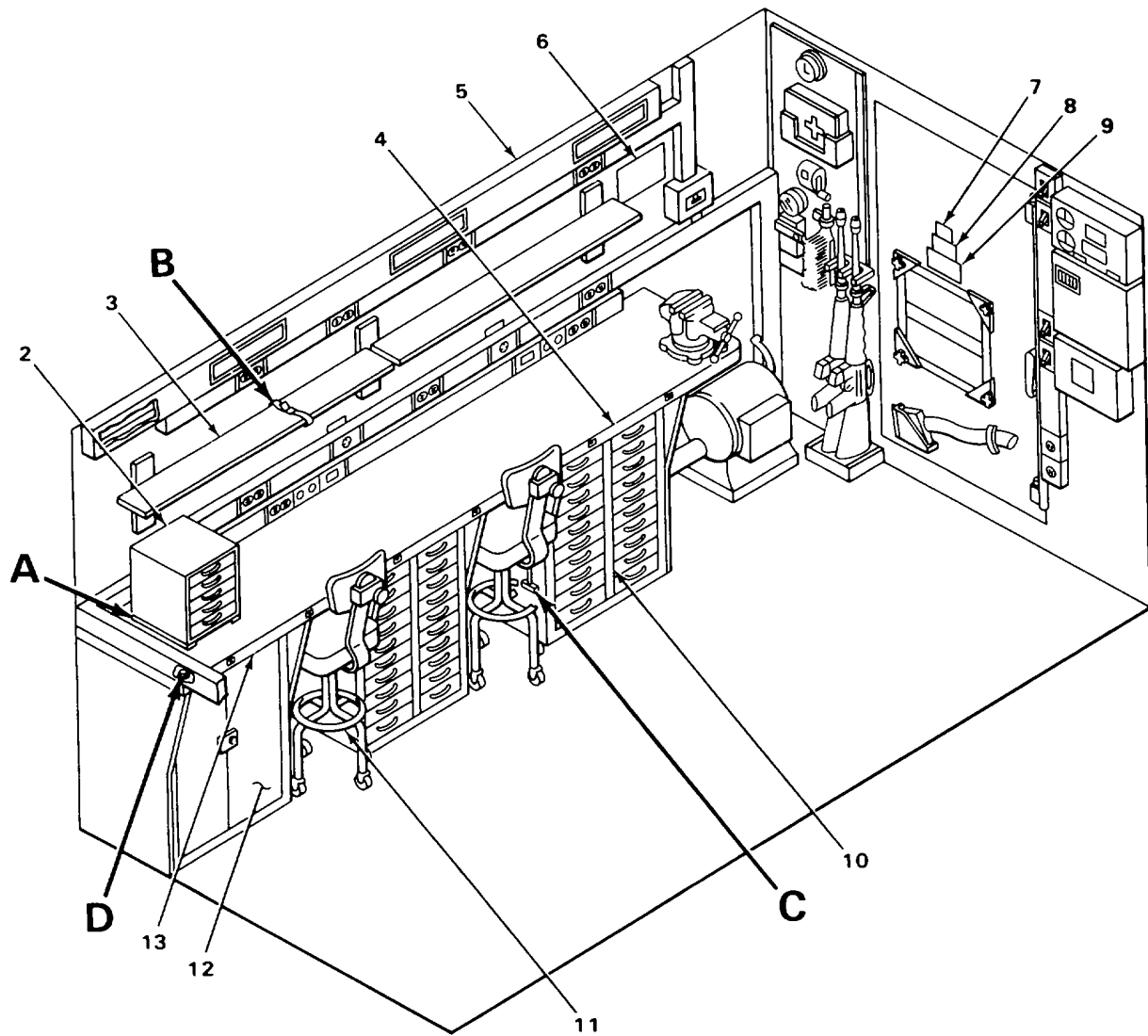

EL8YY007

FIGURE 1. SHELTER, ELECTRONIC EQUIPMENT MAINTENANCE S-639/G (SHEET 2 OF 4)



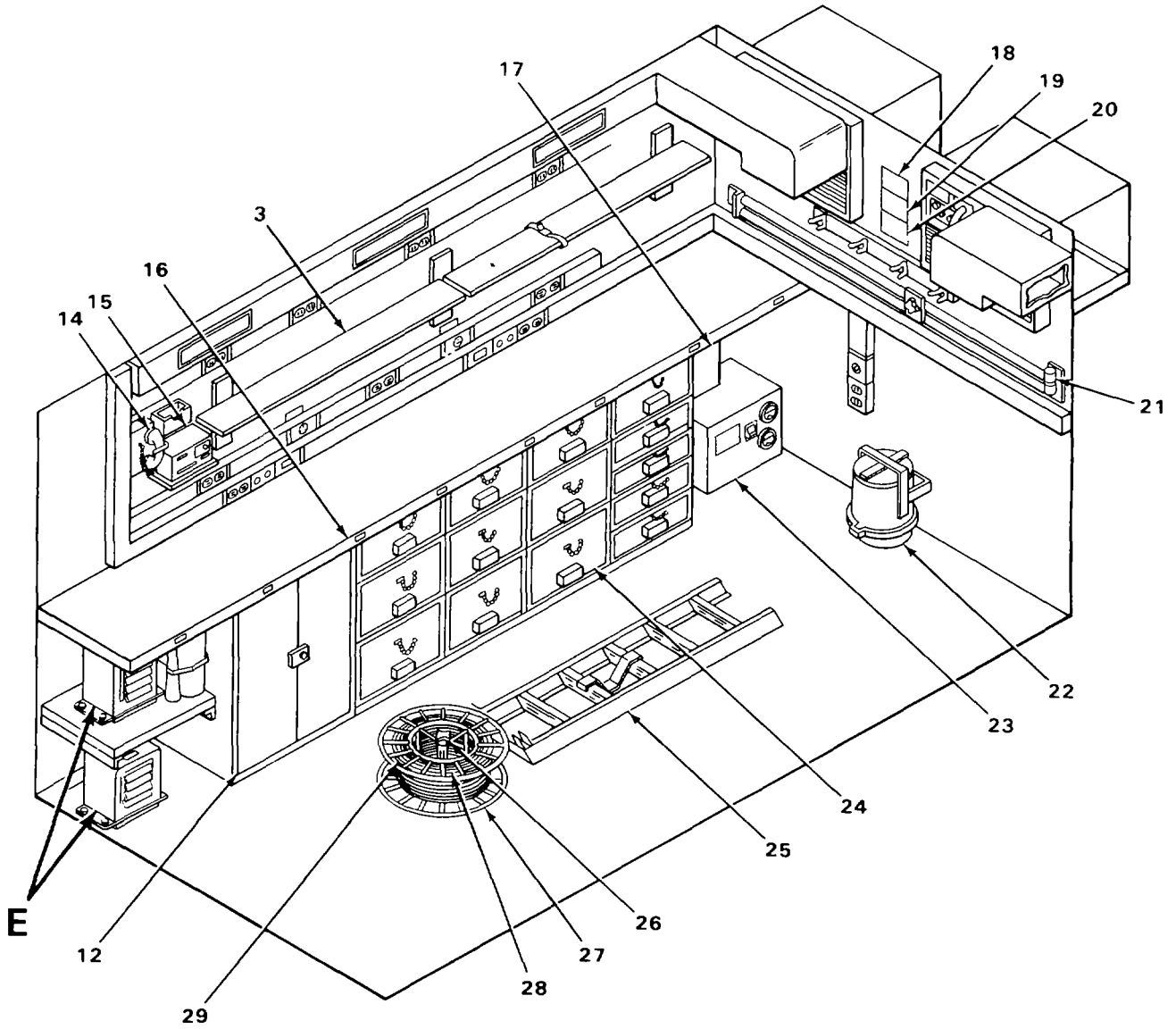

E L8YYO09

FIGURE 1. SHELTER, ELECTRONIC EQUIPMENT MAINTENANCE S-639/G (SHEET 3 OF 4)

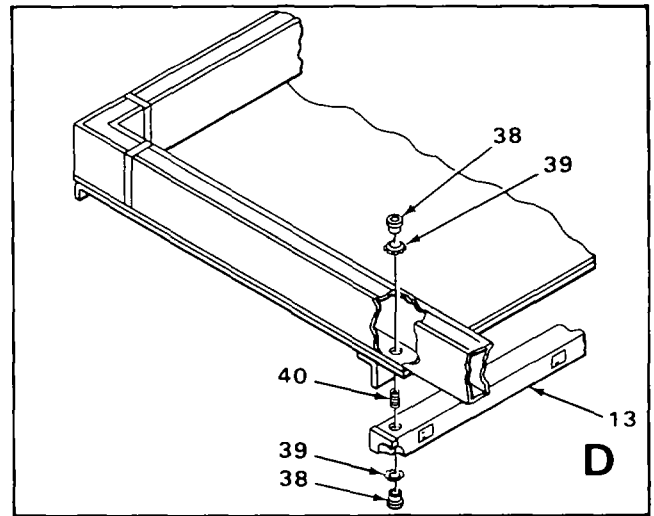
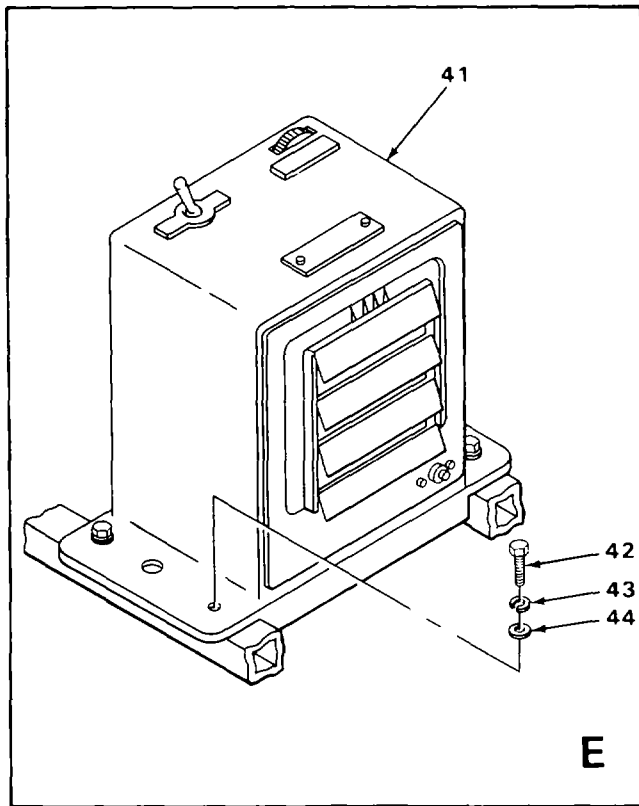
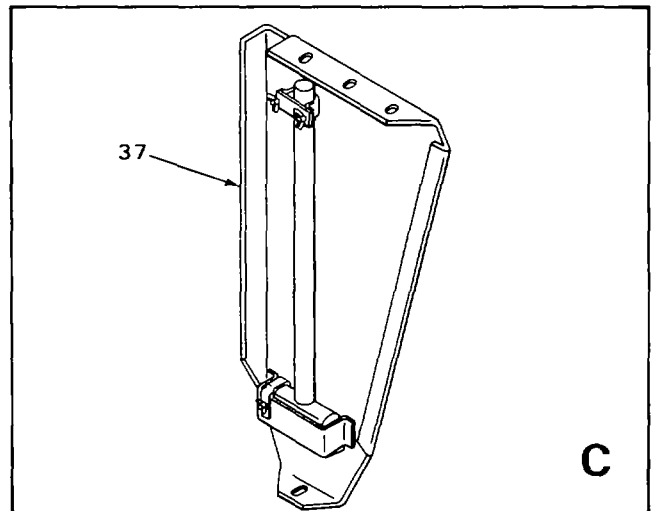
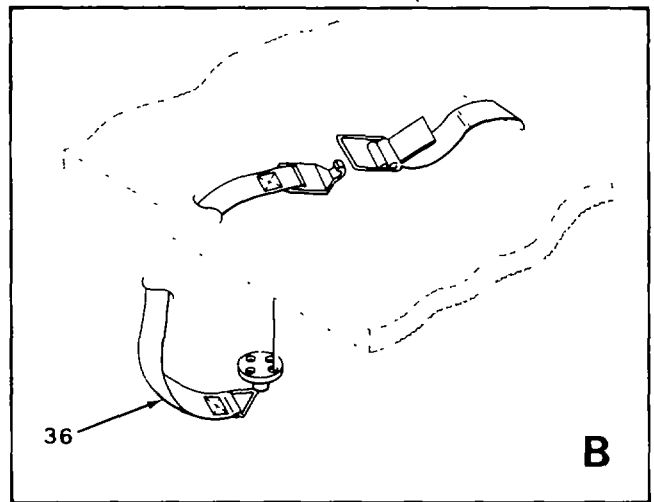
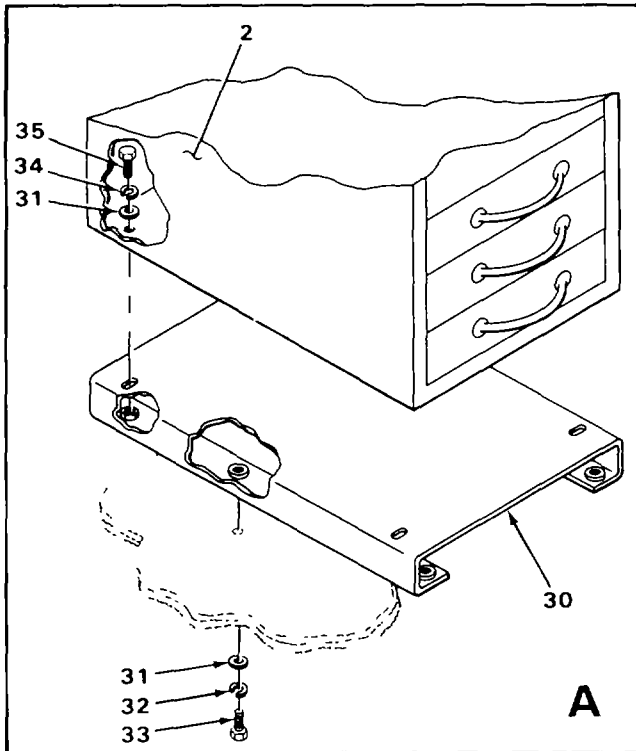

ELBY008

FIGURE 1. SHELTER, ELECTRONIC EQUIPMENT MAINTENANCE S-639/G (SHEET 4 OF 4)

SECTION II

TM 11-5411-211-24P/EE996-AA-PLL-010 E154 S639/TO 35E41 72-4-1

(1) ILLUSTRATION		(2)	(3)	(4)	(5)	(6) DESCRIPTION	(7)	(8)
(a) FIG NO.	(b) ITEM NO.	SMR CODE	NATIONAL STOCK NUMBER	FSCM	PART NUMBER	USABLE ON CODE	U/M	QTY INC IN UNIT
						GROUP 00 SHELTER ELECTRONIC EQUIPMENT MAINTENANCE S-639,G		
1	1	XBOFD		56996	S-639:G	SHLTR ELEK EQPT MAINT S-639/G .....	EA	1
1	2	XBOZZ		56996	84029842	FILE KARDEX .....	EA	1
1	3	XBOZZ		56996	84029812	SHELF .....	EA	4
1	4	XBOZZ		80063	SC-D-681400-3	STRIP RCPTL 44 1/4.....	EA	1
1	5	XBOFF		56996	84029657	BRKT INSTALLATION (SEE FIGURE 2 FOR BREAKDOWN)	EA	1
1	6	XCOZZ		56996	84029747	DIAG PL,PWR WIRING .....	EA	1
1	7	XBOZZ		80063	SC-8-541556	PLATE INFORMATION .....	EA	1
1	8	XBOZZ		80063	SC-B-543939	PLATE CAUTION .....	EA	1
1	9	XBOZZ		80063	SC-B-543934	PLATE WARNING .....	EA	1
1	10	XBOZZ		80063	SC-D-578131	CABINET ASSY.....	EA	1
1	11	XBOZZ		56996	84029730	CHAIR,ROTARY,INSTL.....	EA	2
1	12	XBOZZ		56996	84029676	CABINET ASSEMBLY .....	EA	2
1	13	XBOZZ		80063	SC-D-681400-2	STRIP,RCPTL 72 .....	EA	1
1	14	XBODD		80058	TA-312/T	TELEPHONE SET REFER TO TM11-5805-201-34P...	EA	1
1	15	PAODD	5830-01-008-3126	80058	LS-147F/FI	INTERCOM STATION REFER TO TM11-5830-256-23P	EA	1
1	16	XBOZZ		80063	SC-D-681400-1	STRIP,RCPTL 67 3/4.....	EA	2
1	17	PAOZZ	7520-00-281-5911	58536	A-A-182	BASKET,WASTE .....	EA	1
1	18	XBOZZ		80063	SC-C-629732	PL,WARNING A/C .....	EA	1
1	19	XBOZZ		56996	84035235	PL,INSTR,BLOWER .....	EA	1
1	20	XBOZZ		80063	SC-B-543933	PLATE,WARNING .....	EA	1
1	21	PAOZZ	5975-00-224-5260	80063	MX-148/G	RODS,GROUND.....	EA	2
1	22	XBOZZ		80063	SC-C-916237	CAN,OILY WASTE .....	EA	1
1	23	XBODD		81348	PP-4763A/GRC	POWER SUPPLY REFER TO TM1-5820-765-12 AND TM 11-5820-765-34P-1.....	EA	1
1	24	XBOZZ		56996	84029719	DRAWER ASSY,BENCH.....	EA	1
1	25	PAOZZ		80063	SC-D-108737	LADDER,VEHICLE .....	EA	1
1	26	PAOZZ		80063	SC-D-681416	TIE-DWN ASSEMBLY .....	EA	1
1	27	XBOZZ		80063	SC-B-68449	REEL CABLE.....	EA	1

SECTION II

TM 11-5411-211-24P/EE996-AA-PLL-010 E154 S639/TO 35E41 72-4-1

(1) ILLUSTRATION		(2)	(3)	(4)	(5)	(6) DESCRIPTION	(7)	(8)
(a) FIG NO.	(b) ITEM NO.	SMR CODE	NATIONAL STOCK NUMBER	FSCM	PART NUMBER	USABLE ON CODE	U/M	QTY INC IN UNIT
1	28	XBOFF		80063	SC-D-883963GR7-4	CABLE PWR (SEE FIGURE 11 FOR BREAKDOWN) .	EA	1
1	29	XBOFF		80063	SC-D-883964GR7-2	CABLE PWR (SEE FIGURE 11 FOR BREAKDOWN) .	EA	1
1	30	PAFZZ		80063	SC-D-916230	BRKT ASSY, KARDEX (SEE FIGURE 2 FOR BREAKDOWN)	EA	1
1	31	PAOZZ	5310-00-809-4058	96906	MS27183-10	WASHER FL, 281 I D .....	EA	84
1	32	PAOZZ	5310-00-582-5965	96906	MS35338-44	WASHER LK 250.....	EA	46
1	33	PFOZZ	5305-00-068-0508	96906	MS90728-6	SCREW HEX 250-20X 750.....	EA	8
1	34	PAOZZ	5310-00-045-3296	96906	MS35338-43	WASHER, LK 190.....	EA	10
1	35	PFOZZ	5305-00-087-0259	96906	MS9122-05	SCREW SLOT 190-32X 625.....	EA	6
1	36	XBOZZ		80063	SC-C-947787	STRAP ASSEMBLY (ASSORTED SIZES) .....	EA	V
1	37	XBOZZ		80063	SC-C-539592	HAMMER SLEDGE .....	EA	1
1	38	XBOZZ		80063	SC-C-916191	BUSHING .....	EA	4
1	39	XBOZZ		80063	SC-C-681078-2	NUT LOCK.....	EA	8
1	40	XBOZZ		56996	B4029685	NIPPLE, PIPE .....	EA	2
1	41	PAOFF	4520-00-117-6198	81349	MILH52641	HEATER ASSEMBLY (SEE FIGURE 10 FOR BREAKDOWN) ....	EA	2
1	42	PAOZZ	5306-00-225-8495	96906	MS90725-30	BOLT, MACHINE .....	EA	V
1	43	PAOZZ	5310-00-407-9566	96906	MS35338-45	WASHER LOCK .....	EA	V
1	44	PAOZZ	5310-00-081-4219	96906	MS27183-12	WASHER FLAT .....	EA	V

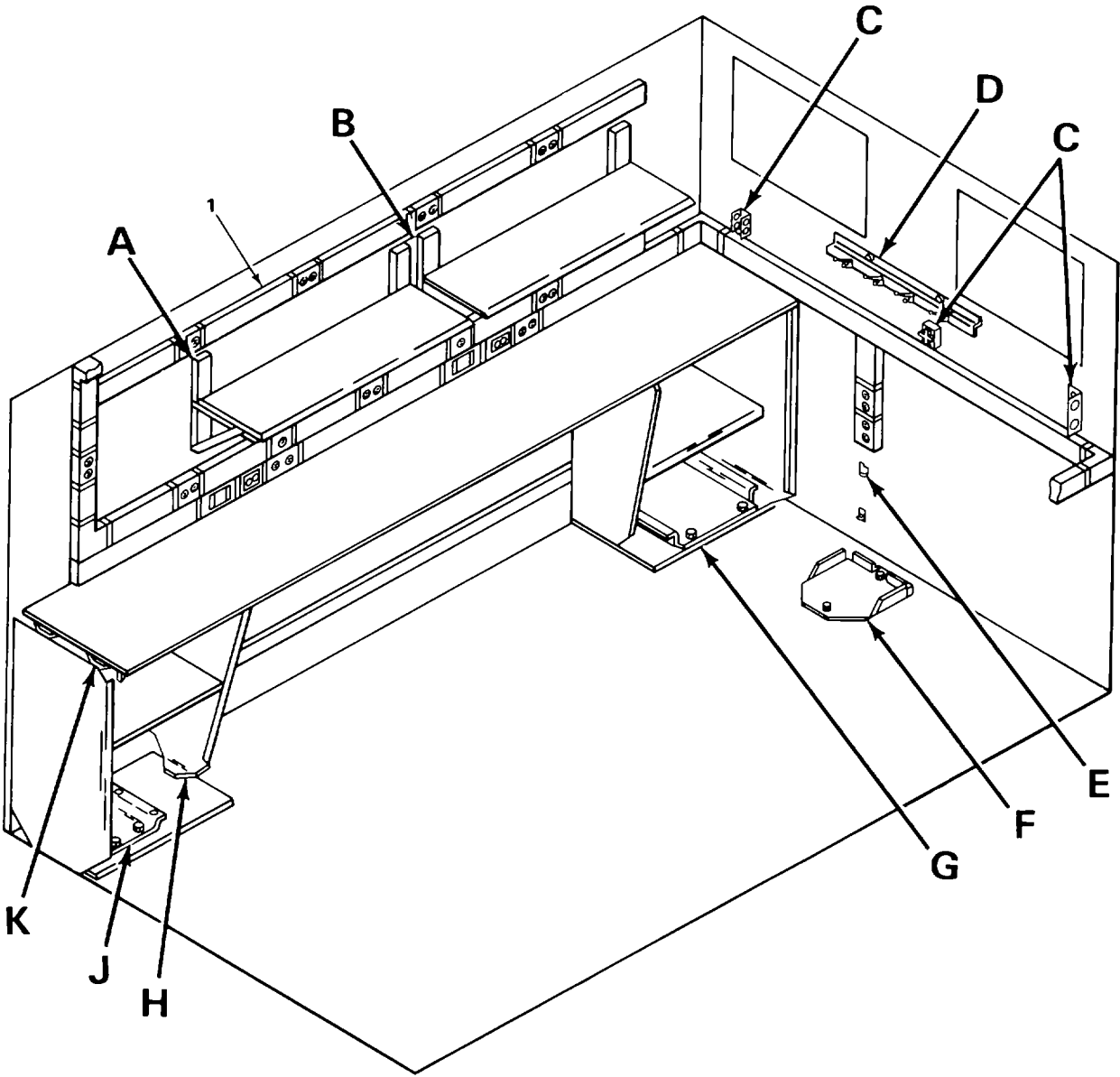

EL8YY013

FIGURE 2. BRACKET INSTALLATION (ROADSIDE AND FRONT WALL) (SHEET 1 OF 4)

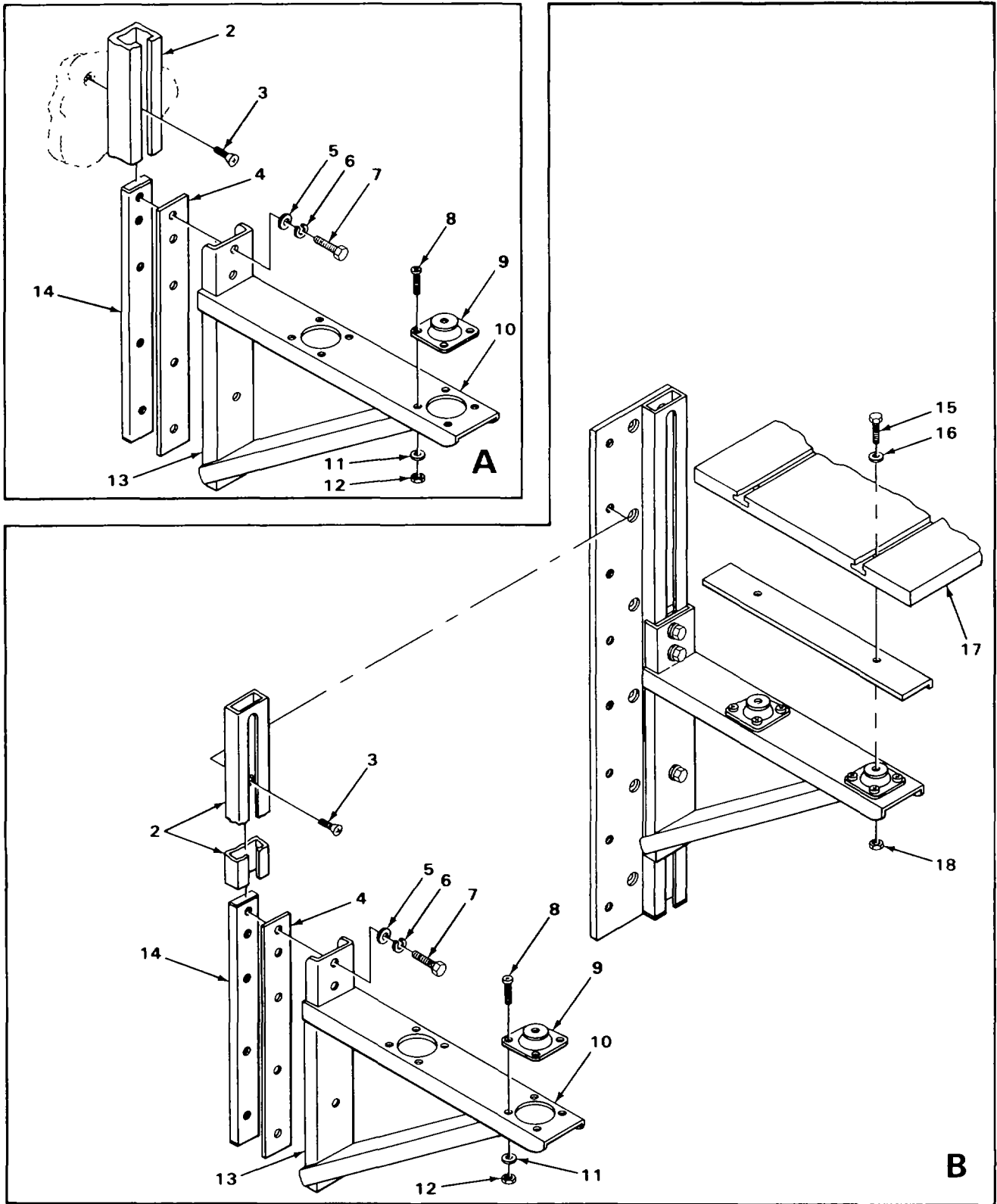

EL8YY014

FIGURE 2. BRACKET INSTALLATION (ROADSIDE AND FRONT WALL) (SHEET 2 OF 4)

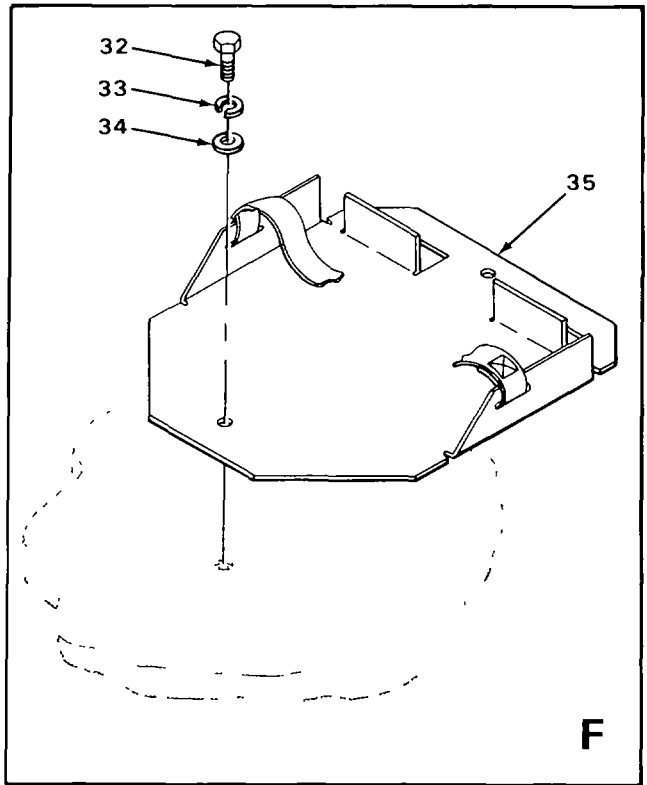
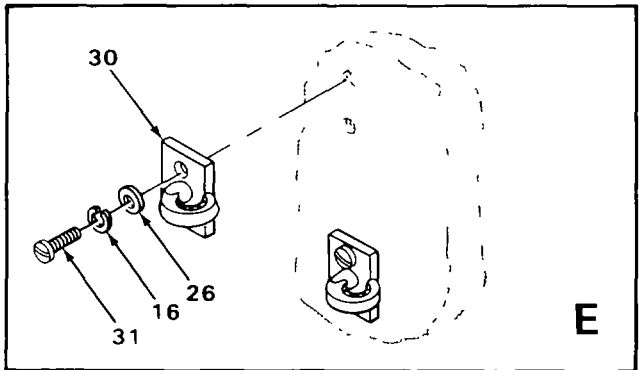
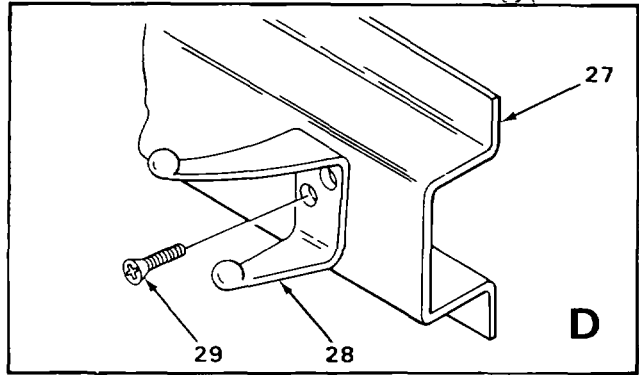
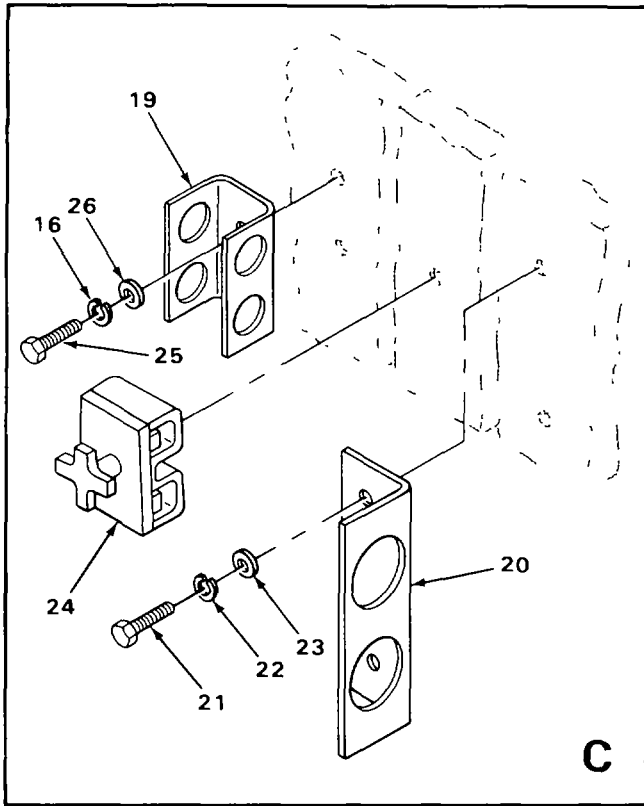

EL8YY015

FIGURE 2. BRACKET INSTALLATION (ROADSIDE AND FRONT WALL) (SHEET 3 OF 4)

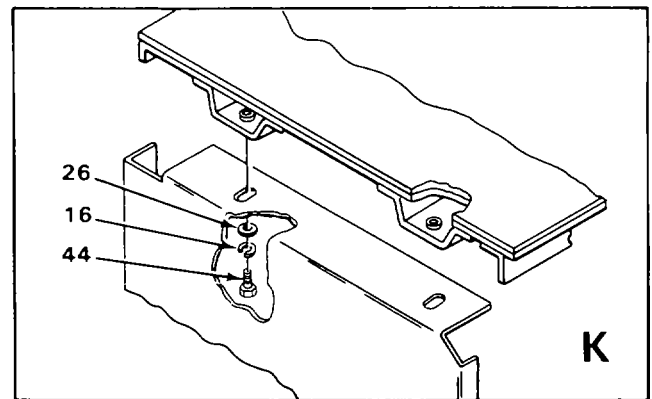
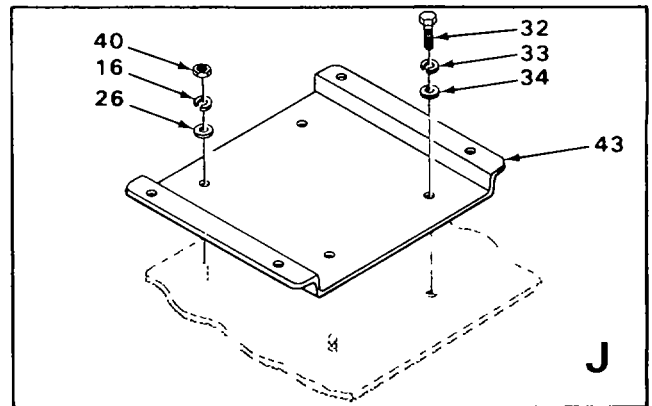
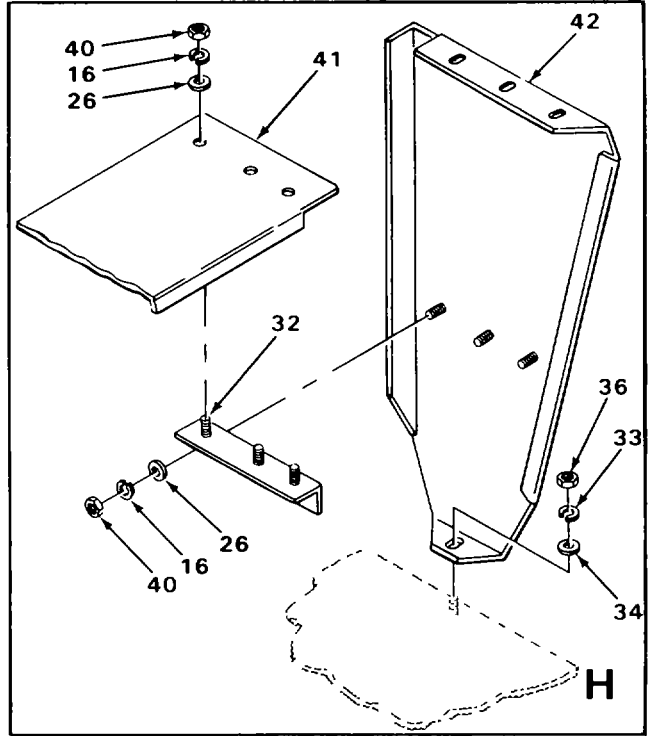
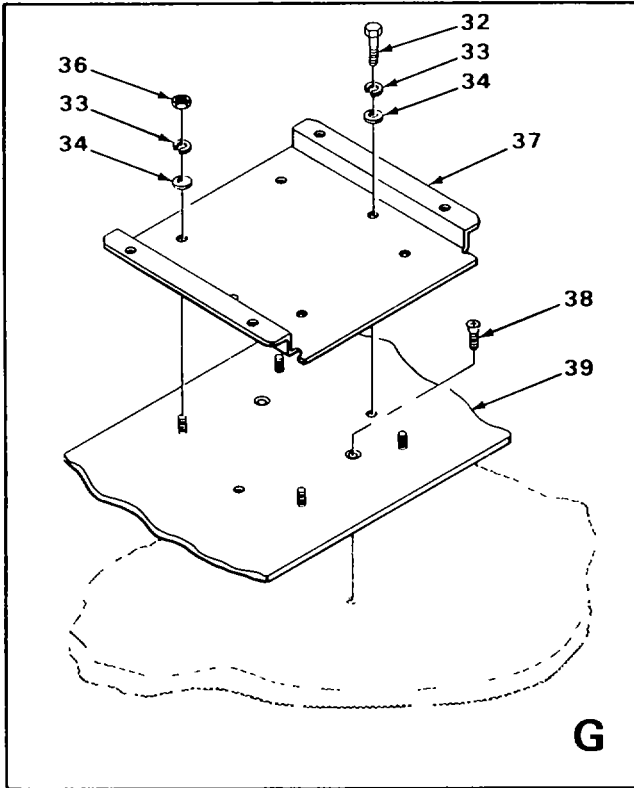

EL8YY016

FIGURE 2 BRACKET INSTALLATION (ROADSIDE AND FRONT WALL) (SHEET 4 OF 4)



SECTION II

(1) ILLUSTRATION		(2)	(3)	(4)	(5)	(6) DESCRIPTION	(7)	(8)
(a) FIG NO.	(b) ITEM NO.	SMR CODE	NATIONAL STOCK NUMBER	FSCM	PART NUMBER	USABLE ON CODE	U/M	QTY INC IN UNIT
						GROUP 01 BRACKET INSTALLATION		
2	1	PAFFF		56996	84029658	UTILITIES INSTAL (SEE FIGURE 4 FOR BREAKDOWN)	EA	1
2	2	XBFZZ		56996	B4029813	BAR CLAMP .....	EA	2
2	3	PAFZZ			NPN	SCREW .....	EA	V
2	4	PAFZZ		56996	B4029811	GASKET RUBBER .....	EA	4
2	5	PAFZZ	5310-00-595-6057	96906	MS15795-815	WASHER FLAT .....	EA	V
2	6	PAFZZ	5310-00-974-6623	96906	MS35338-140	WASHER LOCK .....	EA	V
2	7	PAFZZ	5306-00-225-8497	96906	MS90725-32	SCREW HEXAGON.....	EA	V
2	8	PAFZZ	5305-00-054-6670	96906	MS51957-45	SCREW PH 8-32X 500L.....	EA	16
2	9	XBFZZ		80063	SC-C-916200	MNTNG ISLR SHELF .....	EA	4
2	10	XBFZZ		56996	B4029802	EQUIP SHELF ASSY .....	EA	2
2	11	PAFZZ	5310-00-809-8544	96906	MS27183-7	WASHER FLAT .....	EA	16
2	12	PAFZZ	5310-00-811-3494	96906	MS21044N08	NUT SELF-LOCK 8-32 UNC.....	EA	V
2	13	XBFZZ		56996	84029803	FRAME WELDED ASSY .....	EA	4
2	14	XBFZZ			NPN	BRACKET,MTG.....	EA	1
2	15	PAFZZ	5305-00-071-2510	96906	MS90728-13	SCREW,HEX HD .....	EA	V
2	16	PAFZZ	5310-00-809-4058	96906	MS27183-10	WASHER LOCK .....	EA	V
2	17	XBFZZ		56996	84029812	SHELF .....	EA	2
2	18	PAFZZ	5310-00-984-3806	96906	MS51922-9	NUT SELF LOCK .....	EA	4
2	19	XBFZZ		80063	SC-B-539550-1	BRKT GRND ROD.....	EA	1
2	20	XBFZZ		80063	SC-C-539449	STOP,GRND ROD END .....	EA	1
2	21	PAFZZ	5305-00-958-5247	96906	MS35190-291	SCREW,FL HD .....	EA	4
2	22	XBFZZ			NPN	WASHER,LOCK .....	EA	4
2	23	XBFZZ			NPN	WASHER,FL.....	EA	4
2	24	PAFZZ	5855-01-072-9865	80063	SCC-539421	BRACKET ASSY .....	EA	1
2	25	PAFZZ	5305-00-225-3839	96906	MS90725-8	SCREW HEX HD .....	EA	2
2	26	PAFZZ	5310-00-582-5965	96906	MS35338-44	WASHER,LOCK .....	EA	42
2	27	XBFZZ		80063	SC-C-916218	CLOTHES HANGER ASSY .....	EA	1
2	28	PAFZZ		80063	SC-C-539555	HOOK.....	EA	4

SECTION II

TM 11-5411-211-24P/EE996-AA-PLL-010 E154 S639/TO 35E41 72-4-1

(1) ILLUSTRATION		(2)	(3)	(4)	(5)	(6) DESCRIPTION	(7)	(8)
(a) FIG NO.	(b) ITEM NO.	SMR CODE	NATIONAL STOCK NUMBER	FSCM	PART NUMBER	USABLE ON CODE	U/M	QTY INC IN UNIT
2	29	PAFZZ	5305-00-958-5477	96906	MS35190-254	SCREW CSK HD .....	EA	8
2	30	PAFZZ		80063	SC-B-539517-1	SPRING CLIP .....	EA	2
2	31	PAFZZ	5305-00-988-1727	96906	MS35206-283	SCREW PAN HD .....	EA	4
2	32	PAFZZ	5305-00-225-9081	96906	MS90725-36	SCREW HEX HD .....	EA	54
2	33	PAFZZ	5310-00-407-9566	96906	MS35338-45	WASHER LOCK .....	EA	80
2	34	PAFZZ	5310-00-081-4219	96906	MS27183-12	WASHER FL.....	EA	99
2	35	XBFZZ		56996	84029669	HOLDER ASSEMBLY.....	EA	1
2	36	PAFZZ	5310-00-829-9981	96906	MS35649-2312	NUT HEX 5/16.....	EA	26
2	37	XBFZZ		56996	B4029817	BASE SPRT PWR SUPPL .....	EA	1
2	38	PAFZZ	5305-00-225-8476	96906	MS24693-S144	SCREW FL HD 100 DEG CSK .....	EA	4
2	39	XBFZZ		56996	B4029818	BASE PL PWR SUPPLY .....	EA	1
2	40	PAFZZ	5310-00-997-1888	96906	MS35649-2252	NUT HEXAGON.....	EA	20
2	41	XBFZZ		80063	SC-D-577980	SHELF ASSY .....	EA	1
2	42	XBFZZ		56996	84029677	SHELF,SUPPORT .....	EA	1
2	43	XBFZZ		80063	SC-C-539656	BASE ASSY MNTNG.....	EA	1
2	44	PAFZZ	5305-00-068-0501	96906	MS90725-5	SCREW,HEX HD .....	EA	14

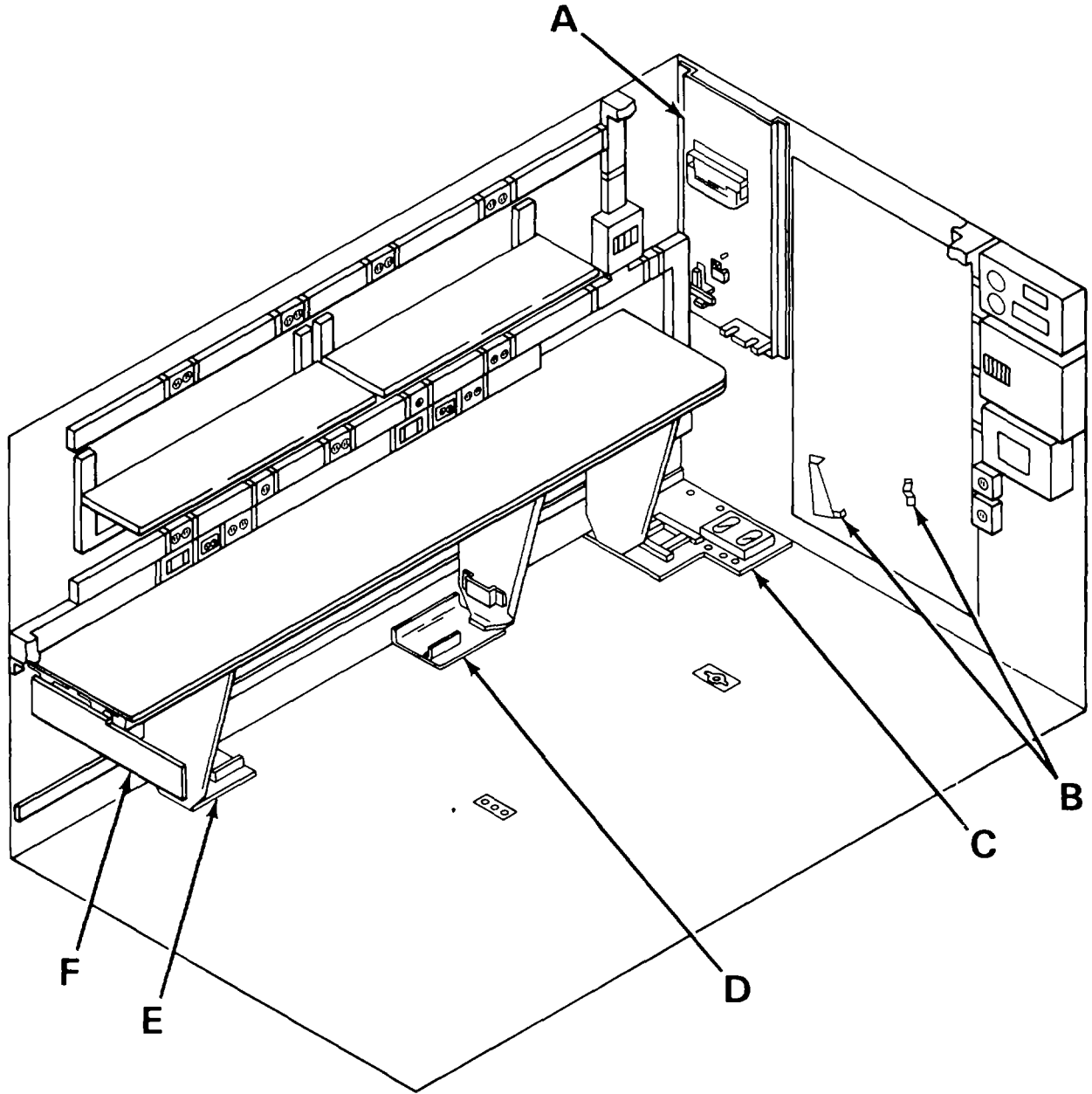
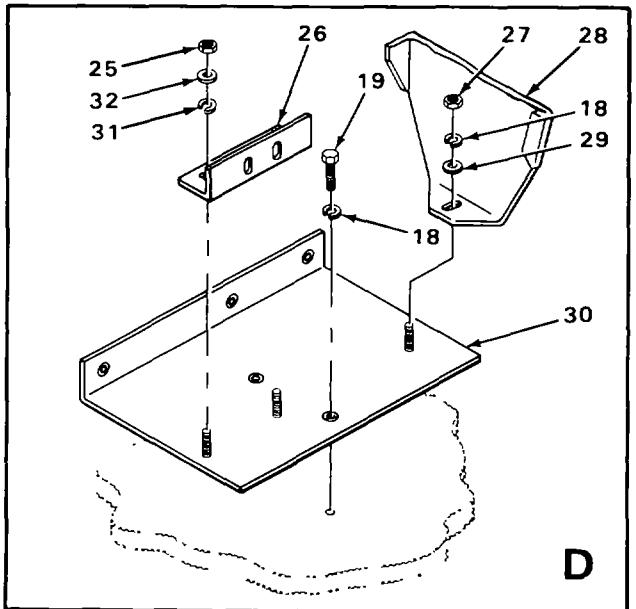
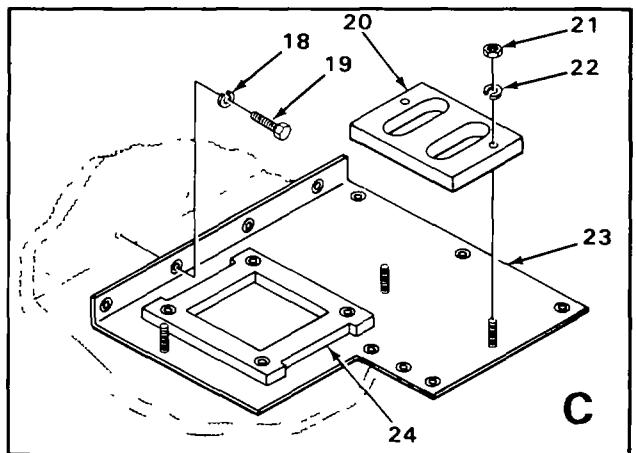
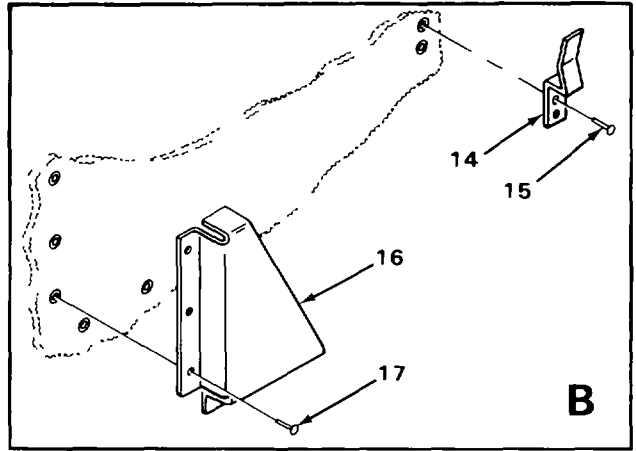
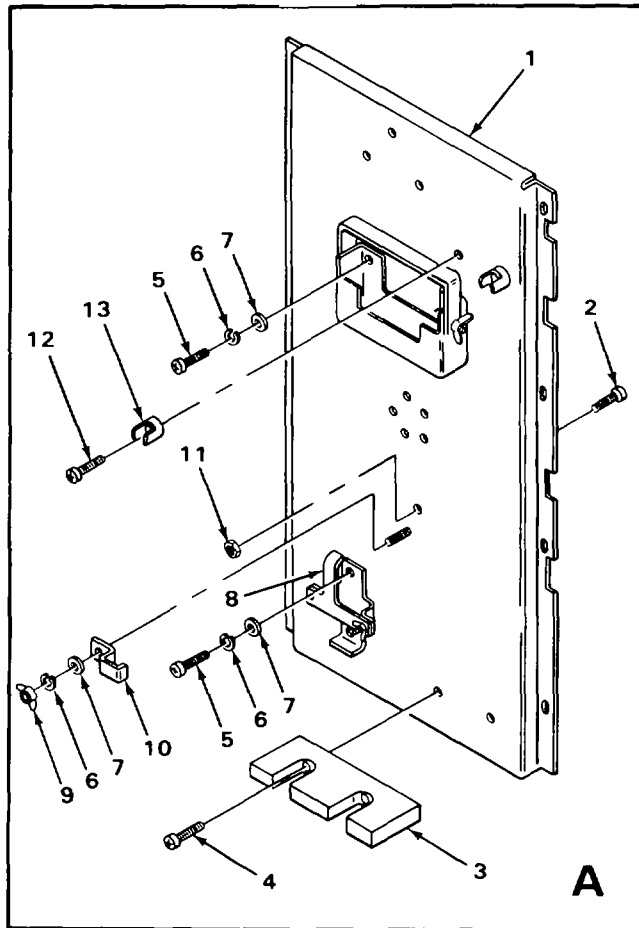

FIGURE 3. BRACKET INSTALLATION (CURBSIDE AND REAR WALL) (SHEET 1 OF 3)

EL8YY017



EL8YY018

FIGURE 3. BRACKET INSTALLATION (CURBSIDE AND REAR WALL) (SHEET 2 OF 3)

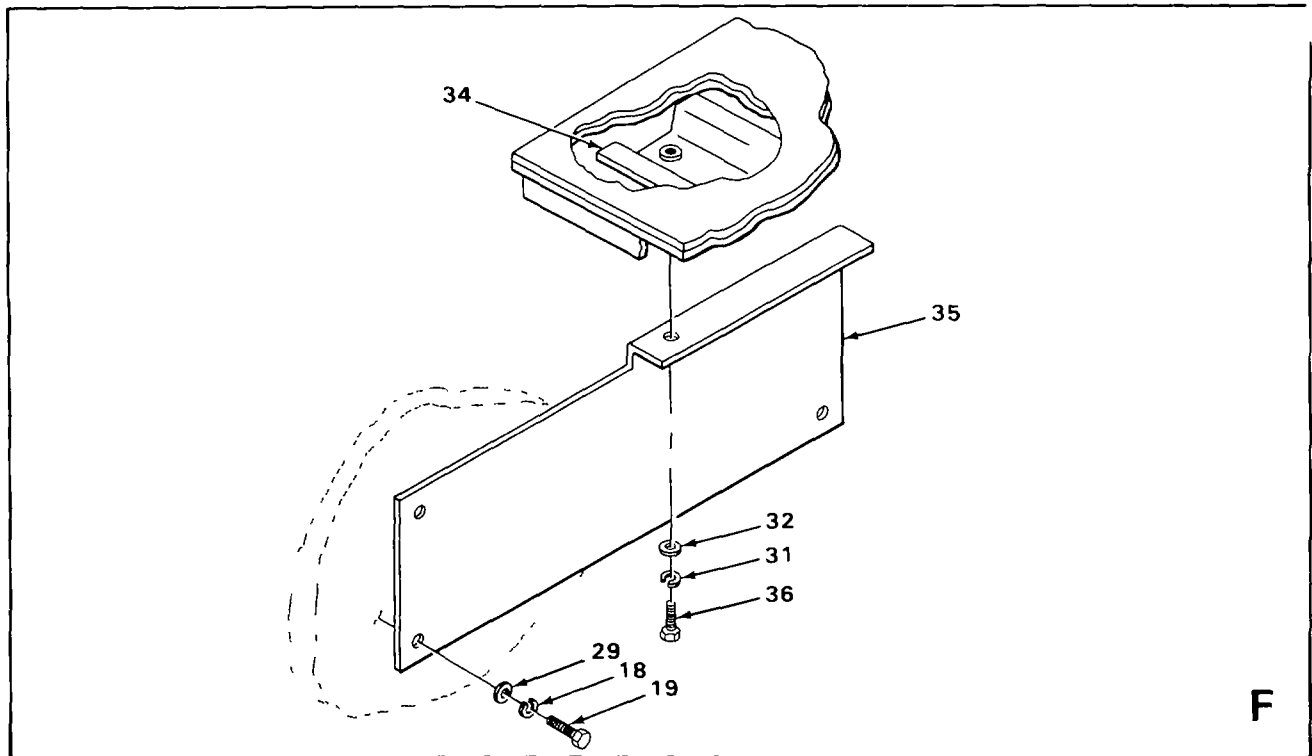
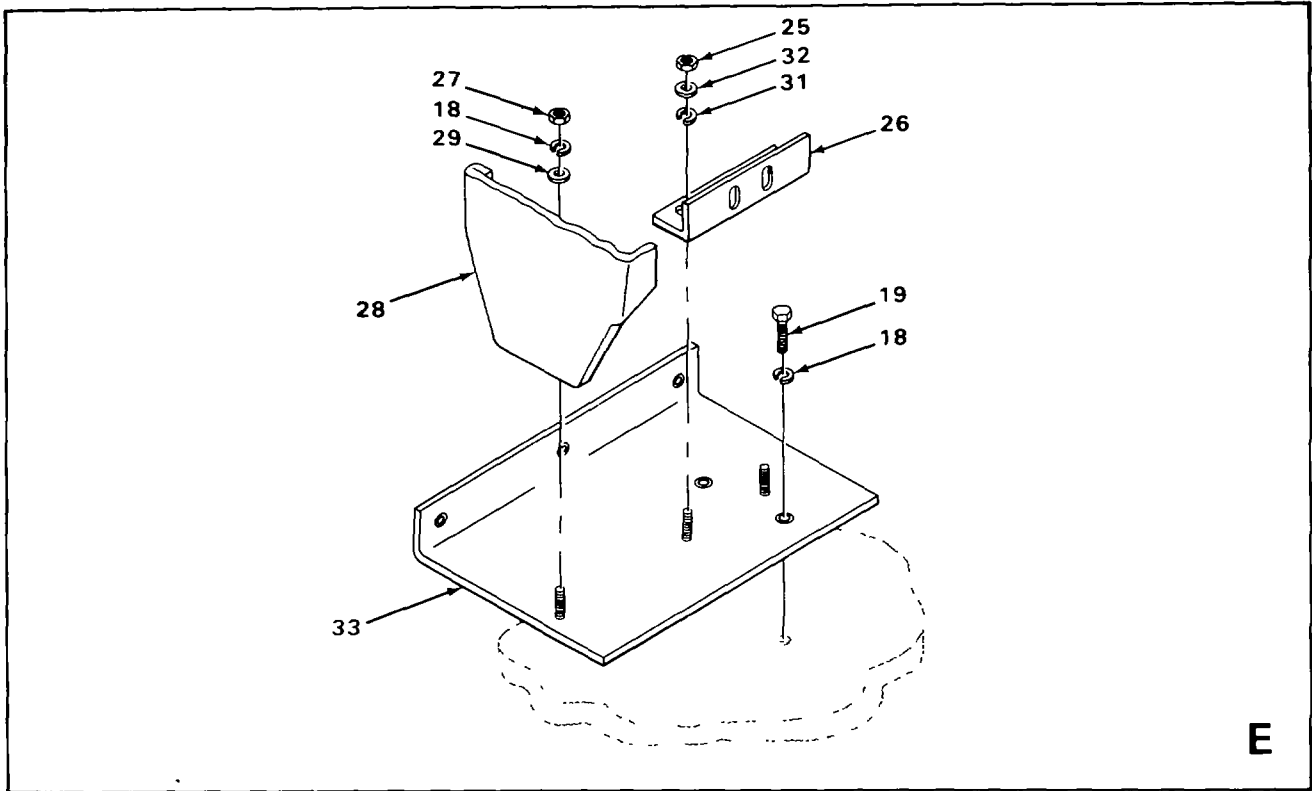

EL8YY040

FIGURE 3. BRACKET INSTALLATION (CURBSIDE AND REAR WALL) (SHEET 3 OF 3)

## SECTION II

TM 11-5411-211-24P/EE996-AA-PLL-0101E154 S639/TO 35E4-172-4-1

(1) ILLUSTRATION		(2)	(3)	(4)	(5)	(6) DESCRIPTION	(7)	(8)
(a) FIG NO.	(b) ITEM NO.	SMR CODE	NATIONAL STOCK NUMBER	FSCM	PART NUMBER	USABLE ON CODE	U/M	QTY INC IN UNIT
3	1	XBFZZ		56996	84029819	COMMON ITEMS PANEL.....	EA	1
3	2	PAFZZ		80063	SC-8-539490	PIN MNTNG.....	EA	1
3	3	PAFZZ	5340-01-094-5434	80063	SC-D-608622	BRKT RIFLE ASSY .....	EA	1
3	4	PAFZZ	5305-00-781-5654	96906	MS24693S97	SCREW CSK HD .....	EA	2
3	5	PAFZZ	5305-00-989-7434	96906	MS35207-263	SCREW PAN HD .....	EA	6
3	6	PAFZZ	5310-00-045-3296	96906	MS35338-43	WASHER LOCK .....	EA	7
3	7	PAFZZ	5310-00-014-5850	96906	MS27183-42	WASHER FLAT .....	EA	7
3	8	PAFZZ	5340-01-169-2882	80063	SC-C-539428	BRKT ASSY LANTERN.....	EA	1
3	9	PAFZZ	5310-00-720-8549	96906	MS35426-13	NUT PLAIN WING .....	EA	1
3	10	PAFZZ	5340-01-023-0504	80063	SC-B-539420	CLAMP ASSEMBLY .....	EA	1
3	11	PAFZZ	5310-00-934-9747	96906	MS35649-262	NUT HEX.....	EA	1
3	12	PAFZZ	5305-00-889-3000	96906	MS35206-230	SCREW PAN HD.....	EA	2
3	13	PAFZZ		80063	SC-B-539474	CLIP .....	EA	2
3	14	XBFZZ		80063	SC-B-539439-1	BRKT AXE HANDLE.....	EA	1
3	15	PAFZZ	5305-00-015-0964	96906	MS35493-262	SCREW WOOD RND HD .....	EA	2
3	16	XBFZZ		80063	SC-D-539460GRI	BRKT ASSEMBLY .....	EA	1
3	17	XBFZZ		80063	SC-C-539759-5	RIVET DOME HEAD.....	EA	5
3	18	PAFZZ	5310-00-407-9566	96906	MS35338-45	WASHER LOCK 5 16 .....	EA	80
3	19	PAFZZ	5305-00-225-9081	96906	MS90725-36	SCREW HEX HD.....	EA	54
3	20	XBFZZ		NPN		RACK RIFLE(BOTTOM) .....	EA	1
3	21	XBFZZ		NPN		NUT HEX HD.....	EA	V
3	22	XBFZZ		NPN		WASHER LOCK .....	EA	V
3	23	XBFZZ		56996	B4035200	BASE ASSY FREQ CONV .....	EA	1
3	24	XBFZZ		56996	B4029736	SUPPORT,BENCH .....	EA	1
3	25	PAFZZ	5310-00-997-1888	96906	MS35649-2252	NUT HEX 1/4-20UNC-2.....	EA	20
3	26	XBFZZ		80063	SM-C-957512	ANGLE CHAIR TIE DOWN.....	EA	2
3	27	PAFZZ	5310-00-829-9981	96906	MS35649-2312	NUT HEX 5 16-18UNC.....	EA	26
3	28	XBFZZ		56996	B4029734	SPRT BENCH CS.....	EA	2

SECTION II

TM 11-5411-211-24P/EE996-AA-PLL-0101E154 S639/TO 35E4-172-4-1

(1) ILLUSTRATION		(2)	(3)	(4)	(5)	(6) DESCRIPTION	(7)	(8)
(a) FIG NO.	(b) ITEM NO.	SMR CODE	NATIONAL STOCK NUMBER	FSCM	PART NUMBER	USABLE ON CODE	U/M	QTY INC IN UNIT
3	29	PAFZZ	5310-00-081-4219	96906	MS27183-12	WASHER FLAT 5 16 .....	EA	99
3	30	XBFZZ		56996	84029738	PL BENCH SPRT .....	EA	1
3	31	PAFZZ	5310-00-582-5965	96906	MS35338-44	WASHER LOCK .....	EA	42
3	32	PAFZZ	5310-00-809-4058	96906	MS27183-10	WASHER FL 1/4 SIZE .....	EA	42
3	33	XBFZZ		56996	B4029739	PL BENCH SPRT .....	EA	1
3	34	XBFZZ		56996	84029779	BRKT TABLE CS .....	EA	1
3	35	XBFZZ		56996	B4029687	BRKT,BENCH SPRT .....	EA	1
3	36	PAFZZ	5305-00-068-0501	96906	MS90725-5	SCREW HEX 1/4-20UNC 5/8 .....	EA	14

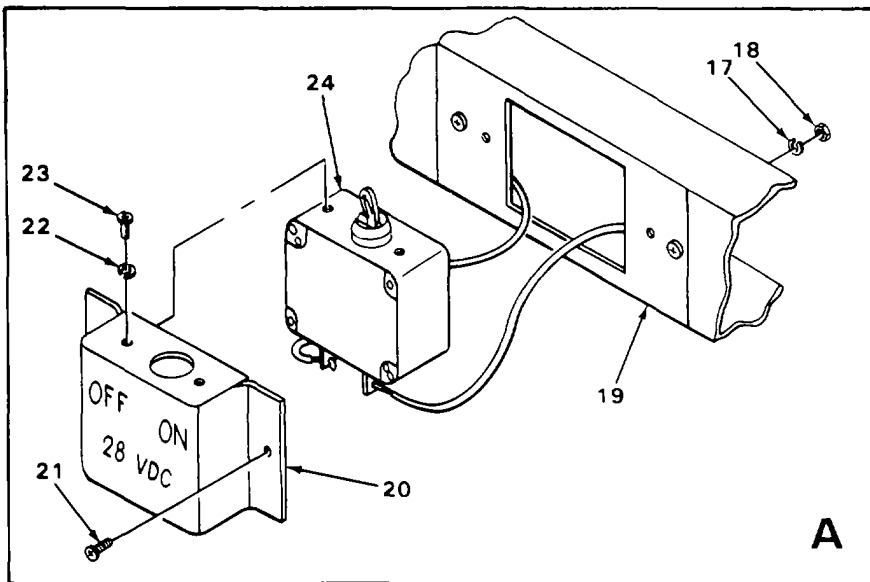
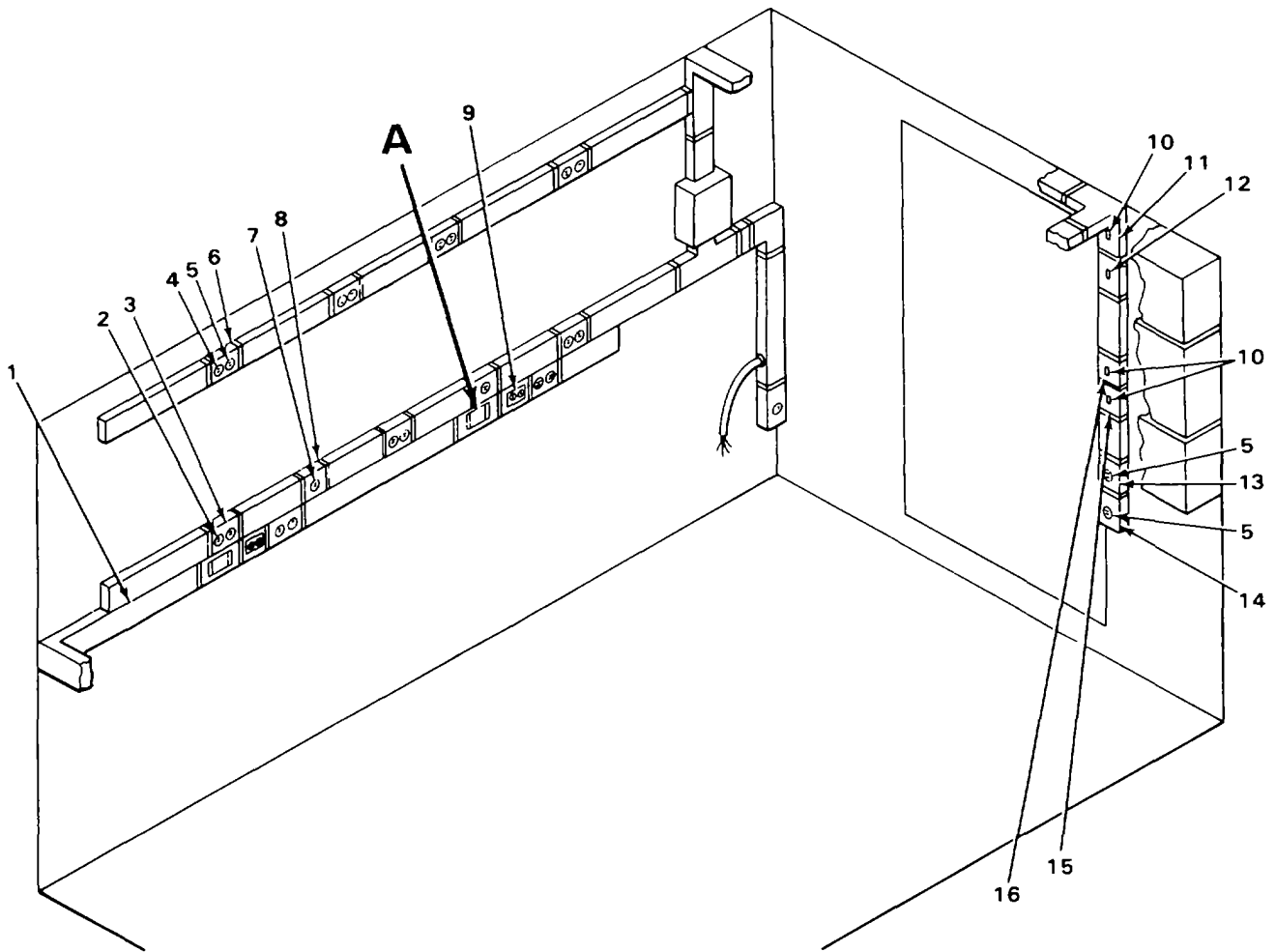

EL8YY027

FIGURE 4. UTILITIES INSTALLATION, ELECTRICAL (SHEET 1 OF 3)



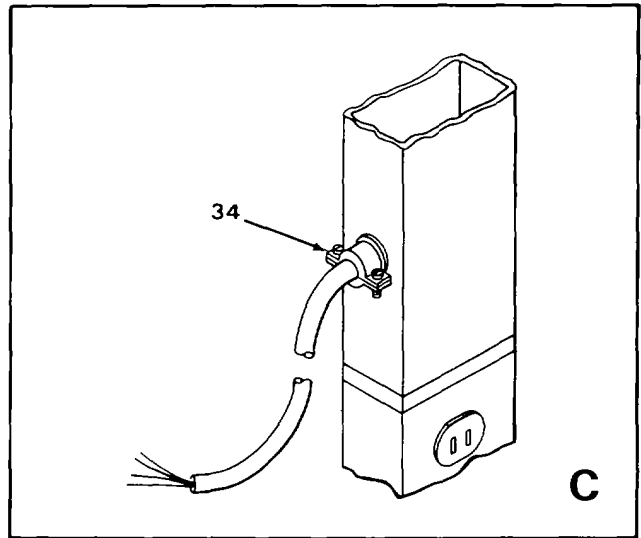
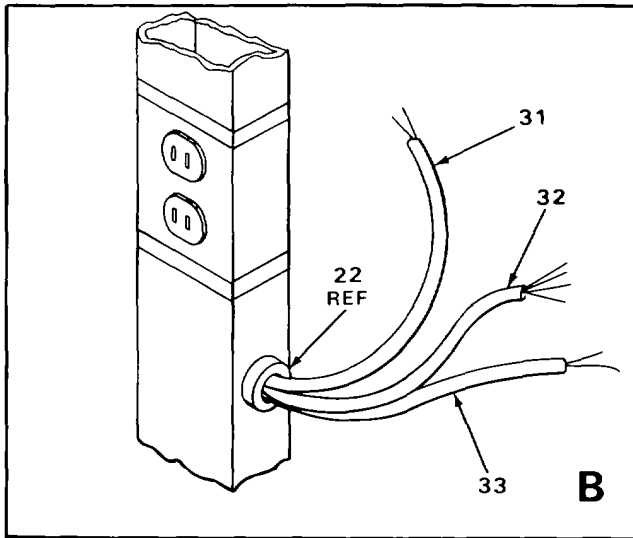
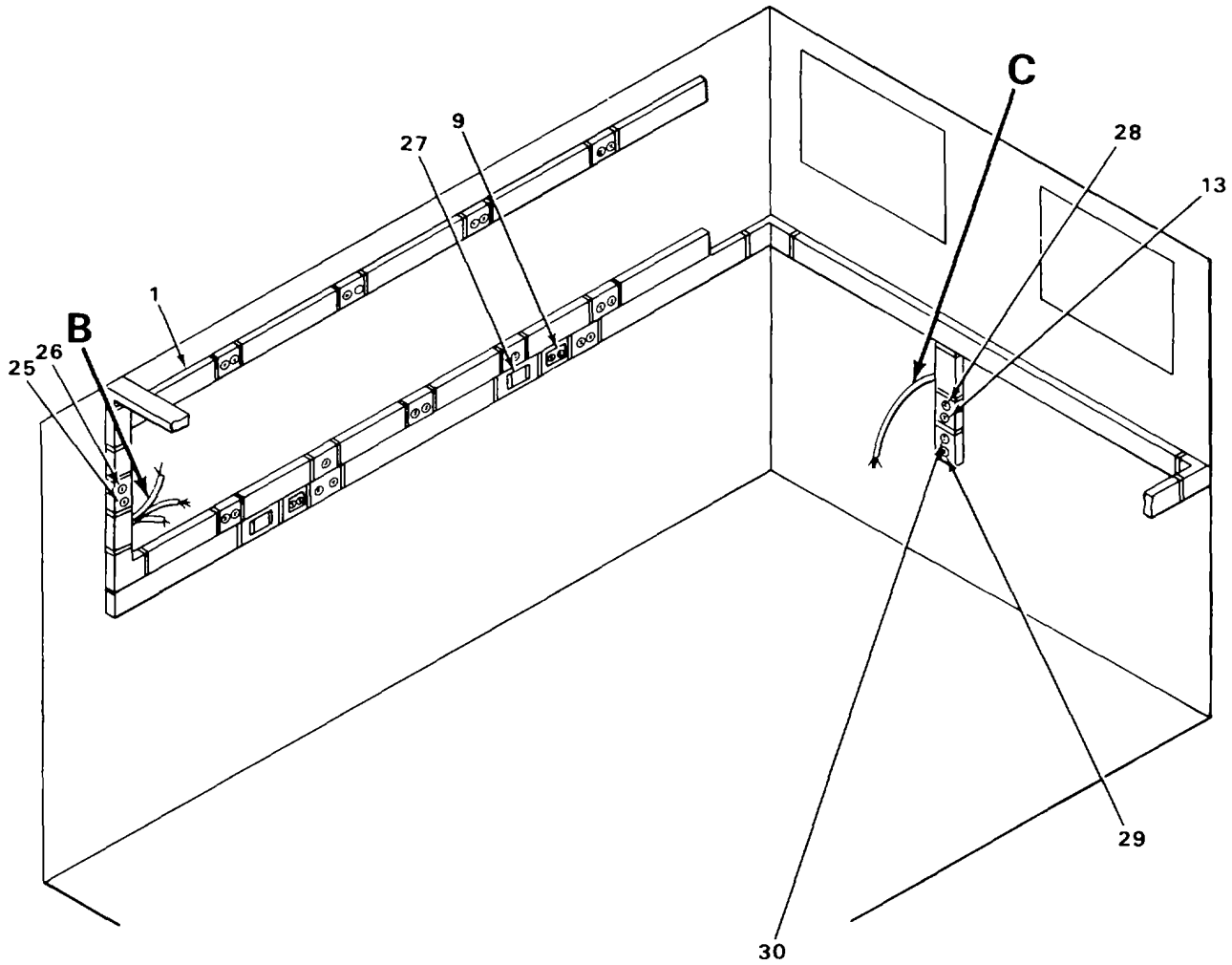

EL8YY026

FIGURE 4. UTILITIES INSTALLATION, ELECTRICAL (SHEET 2 OF 3)

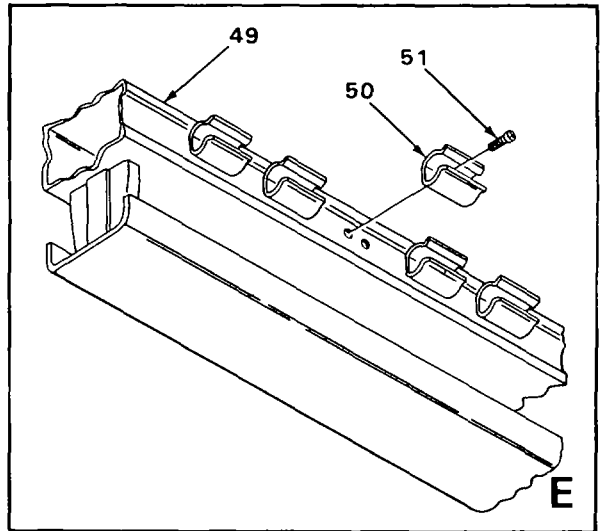
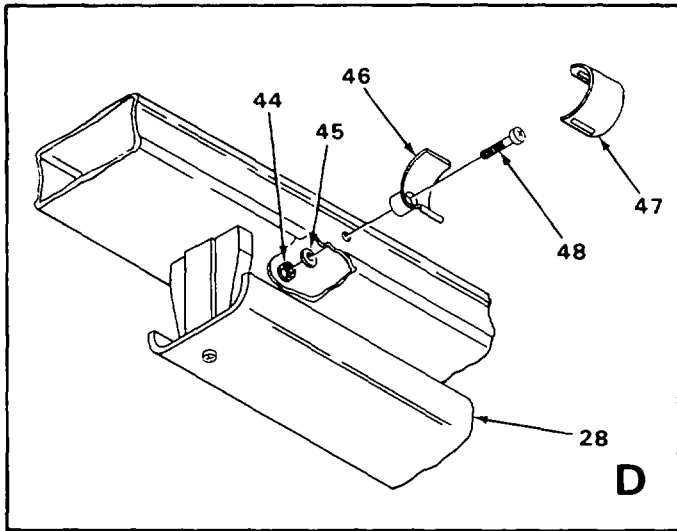
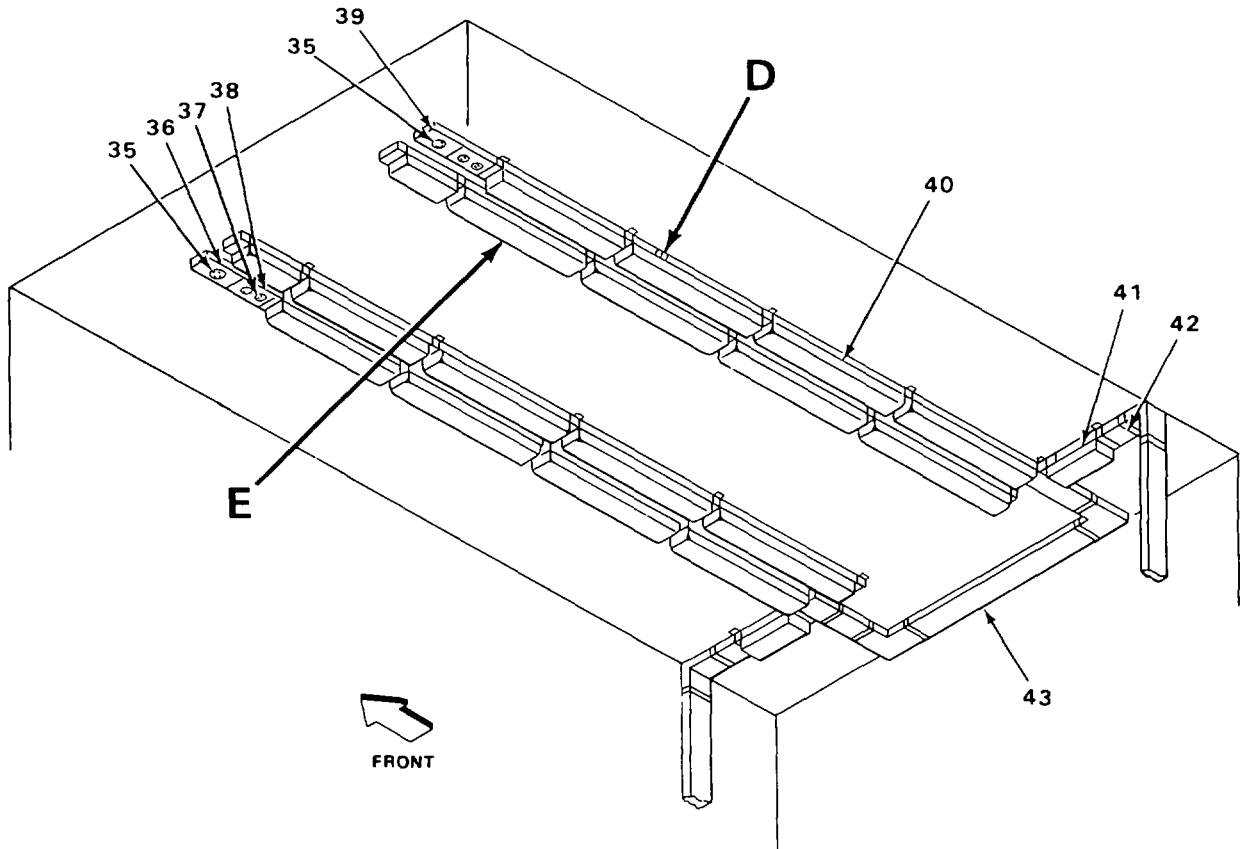

EL8YY028

FIGURE 4. UTILITIES INSTALLATION, ELECTRICAL (SHEET 3 OF 3)

SECTION II

TM 11-5411-211-24P/EE996-AA-PLL-0101E154 S639/TO 35E4-172-4-1

(1) ILLUSTRATION		(2)	(3)	(4)	(5)	(6) DESCRIPTION	(7)	(8)
(a) FIG NO.	(b) ITEM NO.	SMR CODE	NATIONAL STOCK NUMBER	FSCM	PART NUMBER	USABLE ON CODE	U/M	QTY INC IN UNIT
						GROUP 0101 UTILITIES INSTALLATION, ELECTRICAL		
4	1	XBOZZ		56996	B4030004-2	COVER RACEWAY .....	EA	V
4	2	XBOZZ		56996	B4029761-1	CVR RCPT DUPLEX .....	EA	6
4	3	PAOZZ	5935-01-016-3638	81348	WC596/16-1	RECEPTACLE .....	EA	6
4	4	XBOZZ		56996	84029761-2	CVR,RCPT DUPLEX .....	EA	12
4	5	PAOZZ	5935-01-024-4028	80063	WC596/41-2	RECEPTACLE .....	EA	13
4	6	XBOZZ		56996	B4035222-2	CVR,CLIP (GRN) .....	EA	V
4	7	XBOZZ		56996	B4029764-1	CVR RCPT SINGLE .....	EA	4
4	8	XBOZZ	5935-01-036-5170	81348	WC596/28-1	RECEPTACLE .....	EA	4
4	9	XBOZZ		56996	B4029800	BINDING POST ASSY .....	EA	4
4	10	XBOZZ		81348	WS896/3-01	SWITCH .....	EA	4
4	11	XBOZZ		56996	B4029763-1	COVER SWITCH .....	EA	1
4	12	XBOZZ		56996	B4029763-2	COVER,SWITCH .....	EA	1
4	13	XBOZZ		56996	B4029764-2	COVER,RCPT SINGLE .....	EA	2
4	14	XBOZZ		56996	84029764-3	COVER,RCPT,SINGLE .....	EA	2
4	15	XBOZZ		56996	B4029763-4	COVER,SWITCH .....	EA	1
4	16	XBOZZ		56996	84029763-3	COVER SWITCH .....	EA	1
4	17	PAFZZ	5310-00-045-3299	96906	MS35338-42	WASHER,LOCK 28 .....	EA	2
4	18	PAFZZ	5310-00-934-9757	96906	MS35649-282	NUT HEX HD 8 .....	EA	2
4	19	XBOZZ		56996	B4035243	COVER,DEVICE .....	EA	1
4	20	XBFZZ		80063	SC-C-947703	BOX,CRKT BRKR .....	EA	1
4	21	PAFZZ	5305-00-984-6191	96906	MS35206-243	SCREW PH # 8 .....	EA	2
4	22	PAFZZ		96906	MS35489-136	GROMMET .....	EA	1
4	23	PAFZZ	5305-00-984-4982	96906	MS35206-225	SCREW PM ;# 6 .....	EA	2
4	24	XBFZZ		80063	SC-C-947704	CIRCUIT BRKR .....	EA	1
4	25	PAOZZ	5935-00-283-4003	81348	WC00596D7	RECEPTACLE .....	EA	13
4	26	XBOZZ		56996	84029761-3	CVR,RCPT DUPLEX .....	EA	1
4	27	XBFZZ		56996	84029816	CRKT,BRKR BOX .....	EA	4
4	28	XBOZZ		56996	84035288	RCPTL,250V-20A .....	EA	1

SECTION II

TM 11-5411-211-24P/EE996-AA-PLL-0101E154 S639/TO 35E4-172-4-1

(1) ILLUSTRATION		(2)	(3)	(4)	(5)	(6) DESCRIPTION	(7)	(8)
(a) FIG NO.	(b) ITEM NO.	SMR CODE	NATIONAL STOCK NUMBER	FSCM	PART NUMBER	USABLE ON CODE	U/M	QTY INC IN UNIT
4	29	XBOZZ		81348	WC596 77A	RECEPTACLE.....	EA	1
4	30	XBOZZ		56996	B4029793-2	CVR RCPTL SINGLE .....	EA	1
4	31	XBFZZ		56996	84035291	TELEPHONE CA MKG AS .....	EA	V
4	32	XBFZZ		56996	B4035292-2	INTERCOM CA MKG ASS.....	EA	V
4	33	XBFZZ		56996	8403592-1	INTERCOM CA MKG ASS.....	EA	V
4	34	XBOZZ		80063	SC-C-916249	CBL FITTING THRU .....	EA	1
4	35	XBOZZ		80063	SC-C-916192	RECEPTACLE.....	EA	3
4	36	XBOZZ		56996	84029766-2	CVR RCPTL SINGLE .....	EA	1
4	37	XBOZZ		80063	SC-D-681278	RECEPTACLE OUT-SW .....	EA	2
4	38	XBOZZ		56996	84029794	CVR RCPT DUPLEX .....	EA	2
4	39	XBOZZ		56996	B4029766-1	CVR RCPT SINGLE .....	EA	1
4	40	XBOZZ		56996	B4029733	FIXTURE ASSY FLUOR .....	EA	16
4	41	XBOZZ		80063	SC-0-681033	LAMP INCANDESCENT .....	EA	4
4	42	XBOZZ		56996	84035222-1	COVER CLIP (WHT) .....	EA	V
4	43	XBOZZ		56996	84030004-1	CVR RACEWAY (WHT) .....	EA	V
4	44	PAFZZ	5310-00-982-6814	96906	MS21044C08	NUT SLF LOCKING 8-3.....	EA	6
4	45	PAFZZ	5310-00-809-8544	96906	MS27183-7	WASHER FL.....	EA	6
4	46	PAFZZ	5340-01-184-6404	80063	SC-C-539457	CRADLE .....	EA	6
4	47	PAFZZ	5340-01-184-6394	80063	SC-C-539529	CLIP .....	EA	6
4	48	PAFZZ	5305-00-984-6195	96906	MS35206-247	SCREW PH 8-32 .....	EA	6
4	49	XBOFF		56996	B4029659	RACEWAY INSTAL(SEE FIGURE 5 FOR BREAKDOWN)	EA	1
4	50	XBOZZ		80063	SC-C-539440	CLIP STARTER .....	EA	5
4	51	XBOZZ		80063	SC-C-539759-1	RIVET DOME .....	EA	10

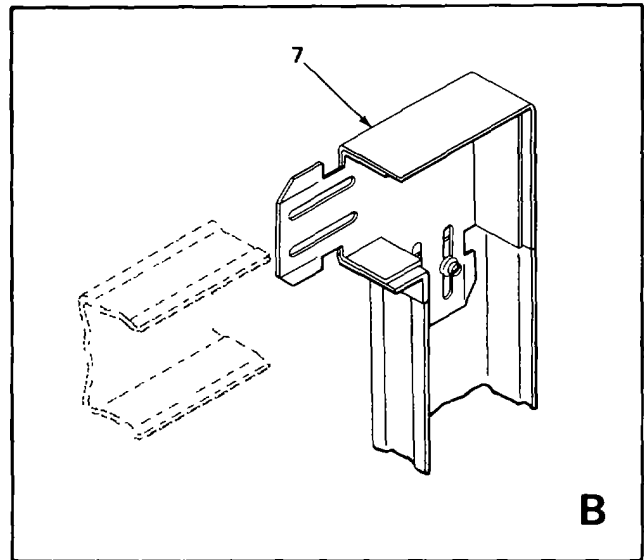
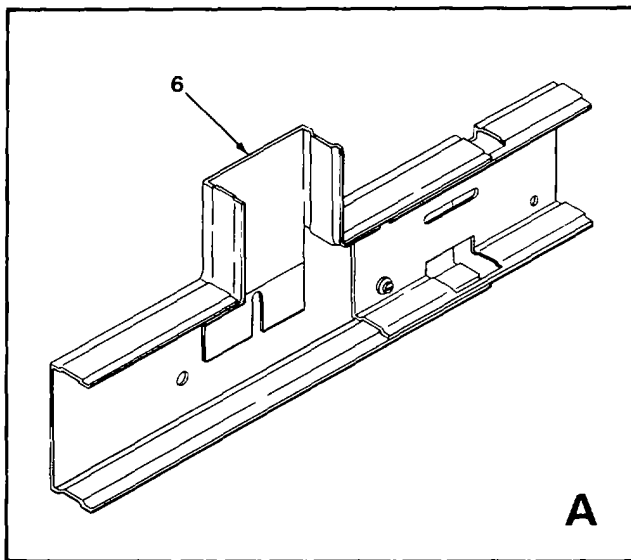
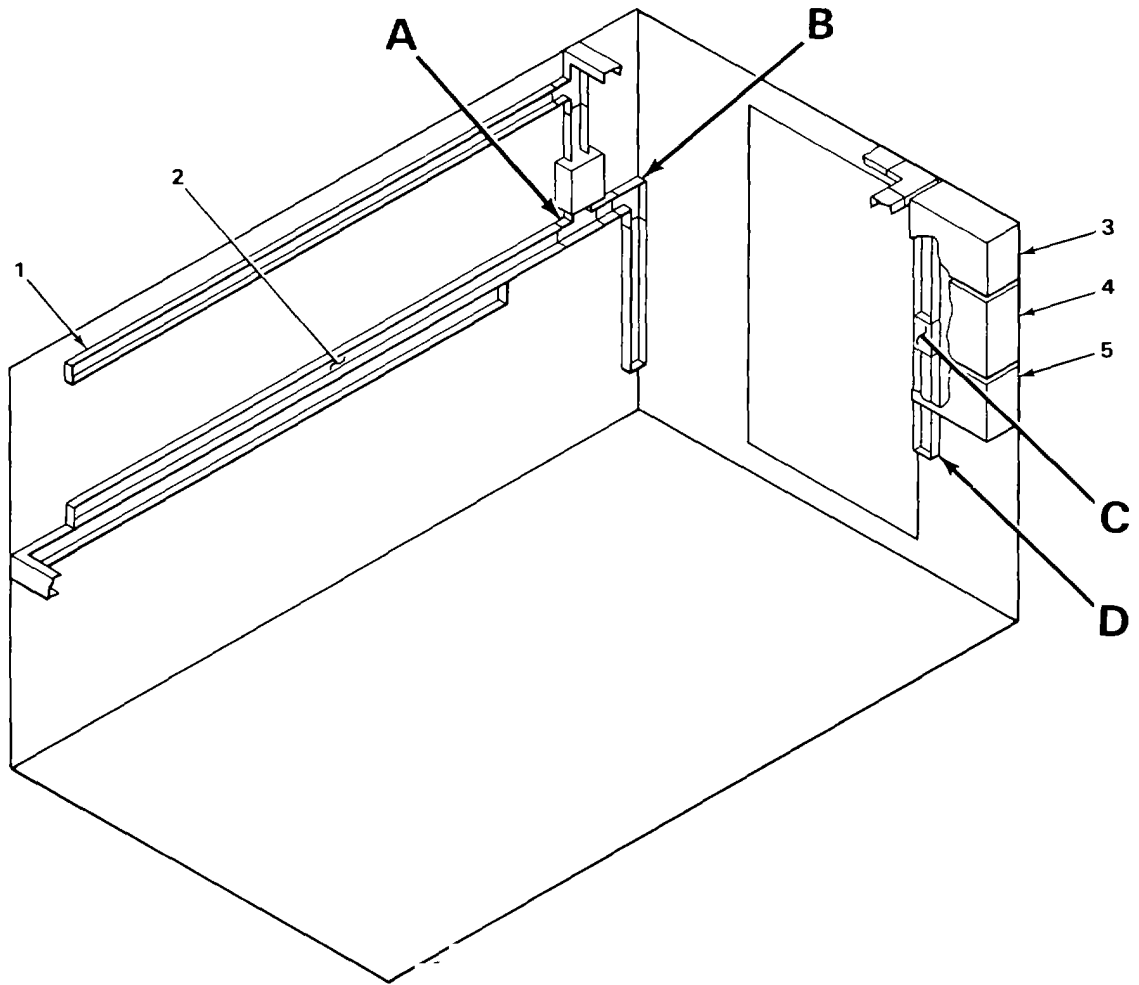

EL8YY029

FIGURE 5. RACEWAY INSTALLATION (ROADSIDE AND REAR WALL) (SHEET 1 OF 2)

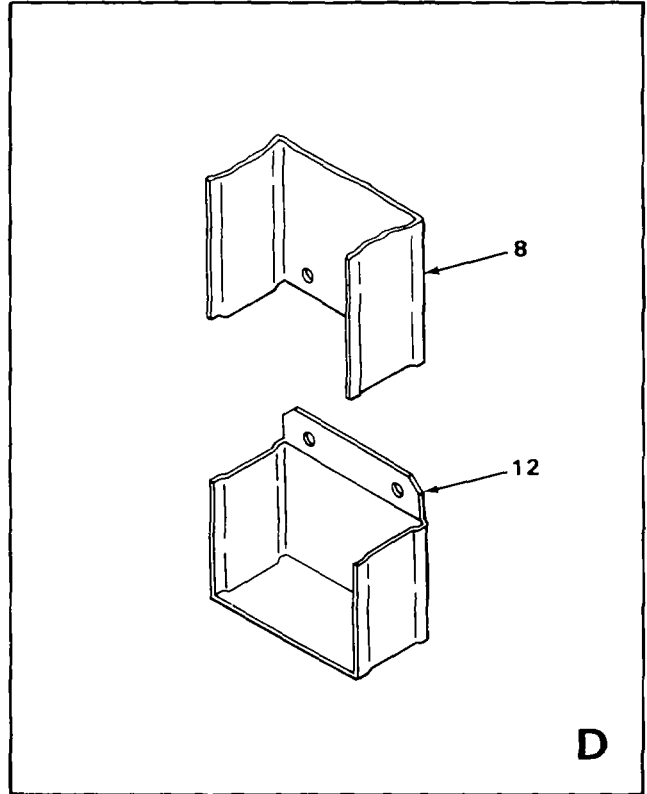
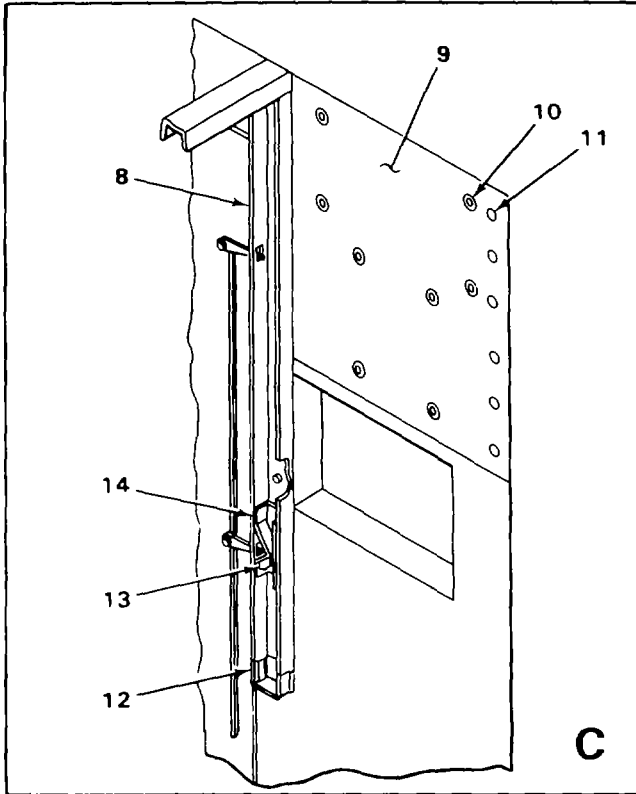

ELSYY030

FIGURE 5. RACEWAY INSTALLATION (ROADSIDE AND REAR WALL) (SHEET 2 OF 2)

SECTION II

TM 11-5411-211-24P/EE996-AA-PLL-0101E154 S639/TO 35E4-172-4-1

(1) ILLUSTRATION		(2)	(3)	(4)	(5)	(6) DESCRIPTION	(7)	(8)
(a) FIG NO.	(b) ITEM NO.	SMR CODE	NATIONAL STOCK NUMBER	FSCM	PART NUMBER	USABLE ON CODE	U/M	QTY INC IN UNIT
						GROUP 010101 RACEWAY INSTALLATION		
5	1	XBFZZ	5930-00-027-2313	80063	SC-B-539586-1	FITTING BLANK END.....	EA	10
5	2	XBFZZ		80063	SC-C-681318-1	RACEWAY BASE .....	EA	V
5	3	XBOFF		56996	84035207	PNL ASSY PWR DISTR(SEE FIGURE 8 FOR BREAKDOWN)	EA	1
5	4	XBOFF		56996	B4029898	FILTER BOX ASSY(SEE FIGURE 9 FOR BREAKDOWN)	EA	1
5	5	XBOOO		56996	84029691	INSTL PWR ENTRANCE(SEE FIGURE 7 FOR BREAKDOWN)	EA	1
5	6	XBFZZ		56996	B4029822-2	TEE .....	EA	4
5	7	XBFZZ		56996	B4029826-3	ELBOW 90 DEG .....	EA	2
5	8	XBFZZ		56996	84029688	RACEWAY BASE MOD.....	EA	1
5	9	XBFZZ		56996	B4029689	PLATE,MOUNTING .....	EA	1
5	10	XBFZZ		80063	SC-C-681398-4	RIVET CSK HD 120 DE.....	EA	12
5	11	XBFZZ		80063	SC-D-681075-38	NUT RIVET 1/4-20UNC .....	EA	8
5	12	XBFZZ		80063	SC-B-539586-2	FITTING BLANK END.....	EA	10
5	13	PAFZZ		91929	BZ-2RQ18T	SWITCH,MICRO.....	EA	1
5	14	XBFZZ		80063	SC-C-916263	CPLNG ASSY,MICRO SW .....	EA	1

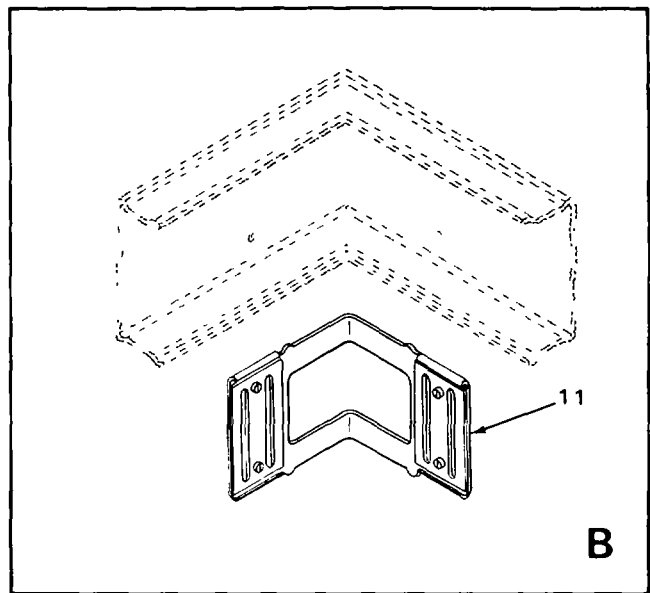
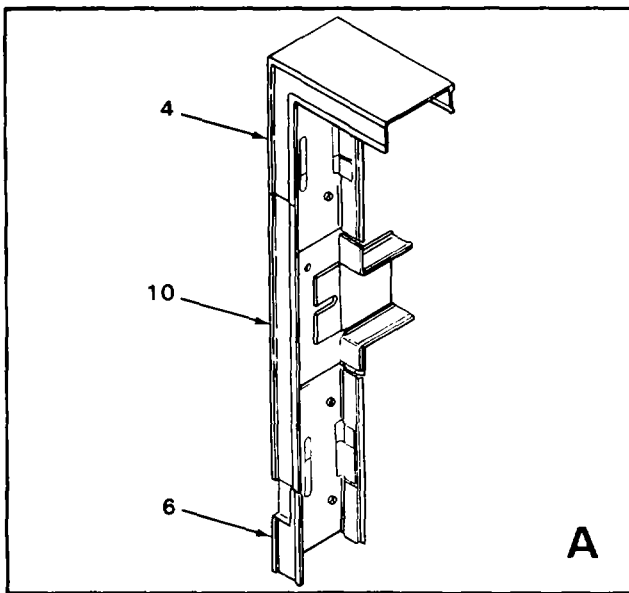
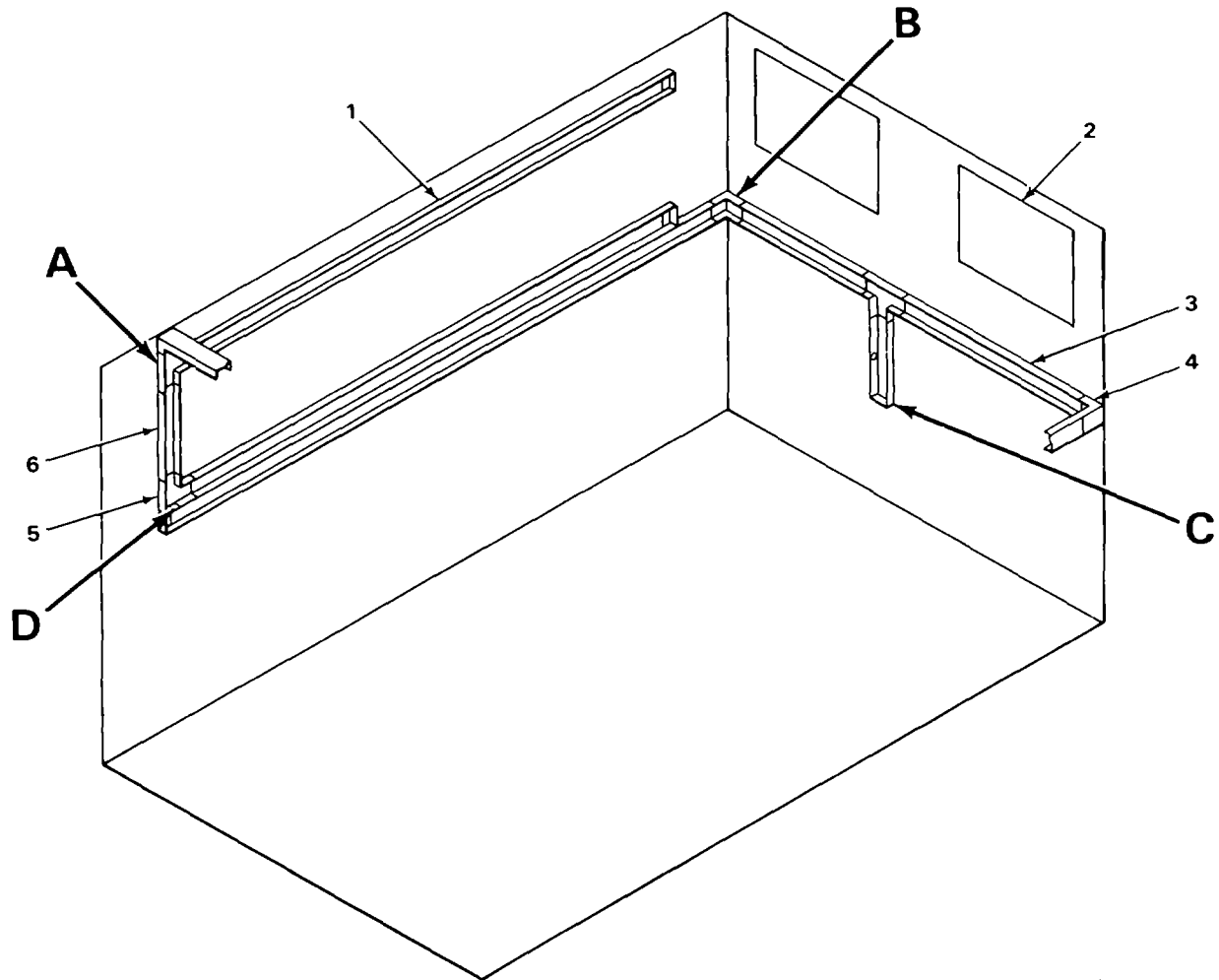

EL8YY031

FIGURE 6. RACEWAY INSTALLATION (CURBSIDE, FRONT WALL AND CEILING) (SHEET 1 OF 3)



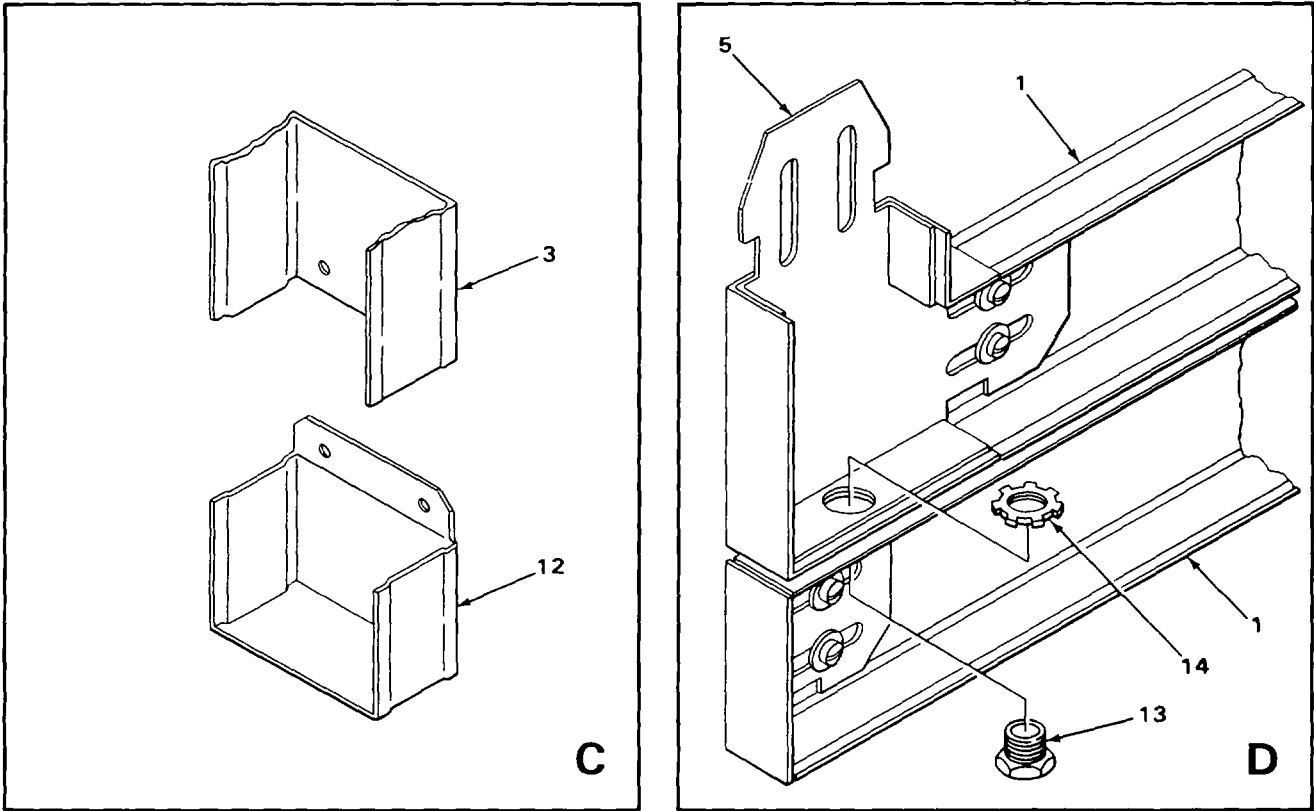

EL8YY032

FIGURE 6. RACEWAY INSTALLATION (CURBSIDE, FRONT WALL AND CEILING) (SHEET 2 OF 3)

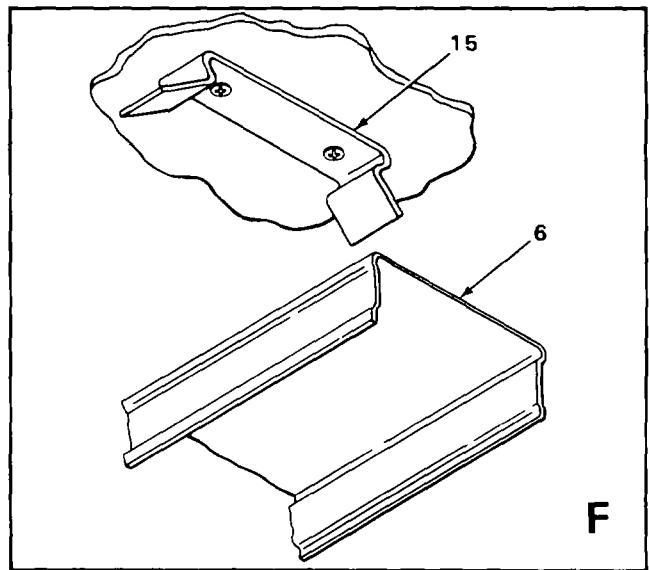
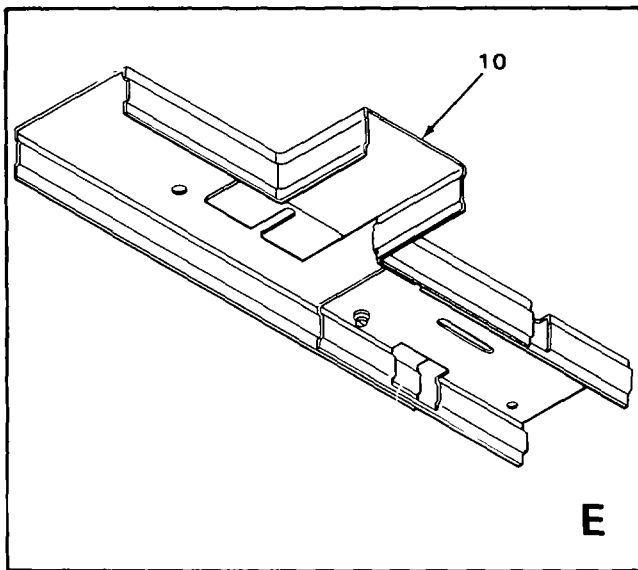
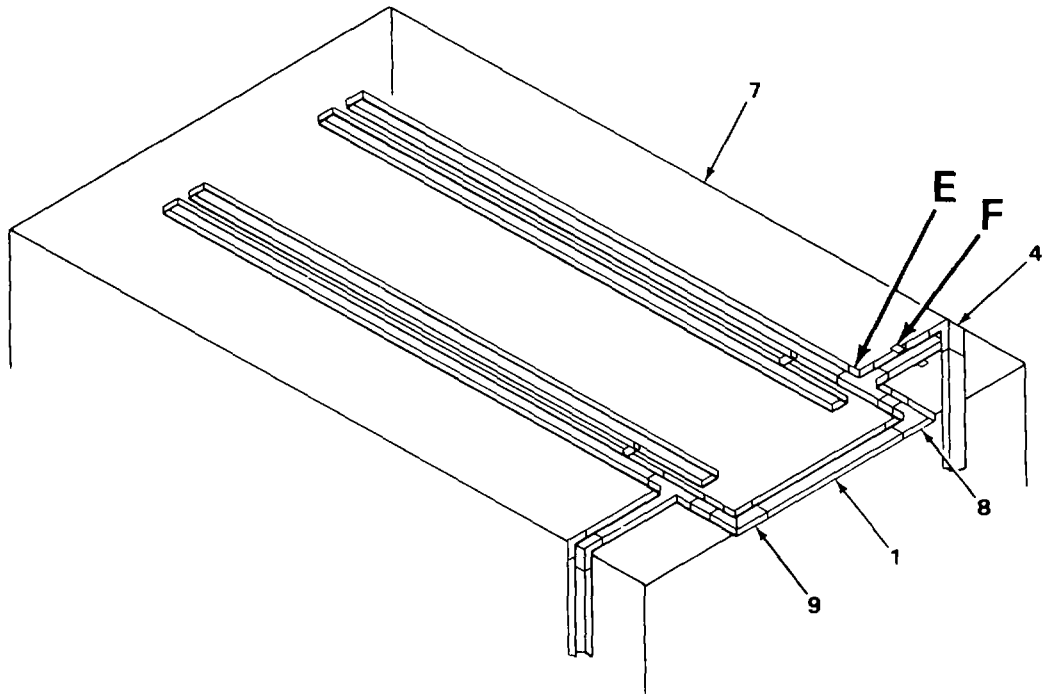

EL8YY033

FIGURE 6. RACEWAY INSTALLATION (CURBSIDE, FRONT WALL AND CEILING) (SHEET 3 OF 3)

SECTION II

TM 11-5411-211-24P/EE996-AA-PLL-0101E154 S639/TO 35E4-172-4-1

(1) ILLUSTRATION		(2)	(3)	(4)	(5)	(6)	(7)	(8)
(a) FIG NO.	(b) ITEM NO.	SMR CODE	NATIONAL STOCK NUMBER	FSCM	PART NUMBER	DESCRIPTION  USABLE ON CODE	U/M	QTY INC IN UNIT
6	1	XBOZZ		80063	SC-C-681318-2	RACEWAY BASE (W) .....	EA	V
6	2	XBOFF		56996	B4029690	ECU INSTALLATION .... REFER TO TM5-4120-239-14	EA	1
6	3	XBFZZ		80063	SC-C-681318-1	RACEWAY BASE (G) .....	EA	V
6	4	XBFZZ		80063	SC-B-539583-3	COUPLING, INT CORNER .....	EA	4
6	5	XBFZZ		56996	B4035270	ELBOW 90 DEG .....	EA	1
6	6	XBFZZ		56996	B4035272	BASE, RACEWAY .....	EA	1
6	7	XBODD		56996	B4029660	SHELTER MODIFIED ..... REFER TO TM11-5410-213-14P AND TB750-240	EA	1
6	8	XBFZZ		80063	SC-C-916223	ELBOW, 90 DEG .....	EA	1
6	9	XBFZZ		56996	B4029826-4	ELBOW, 90 DEG .....	EA	2
6	10	XBFZZ		56996	B4029822-1	TEE .....	EA	4
6	11	XBFZZ		80063	SC-B-681053	CPLG INSIDE RGD .....	EA	1
6	12	XBFZZ		80063	SC-B-539586-1	FITTING, BLANK END .....	EA	10
6	13	XBFZZ		56996	SC-C-6810777	NIPPLE, CHASE .....	EA	1
6	14	XBFZZ		80063	SC-C-681078-2	LOCKNUT .....	EA	1
6	15	XBFZZ		56996	B4035317-001	CLIP, COVER .....	EA	V

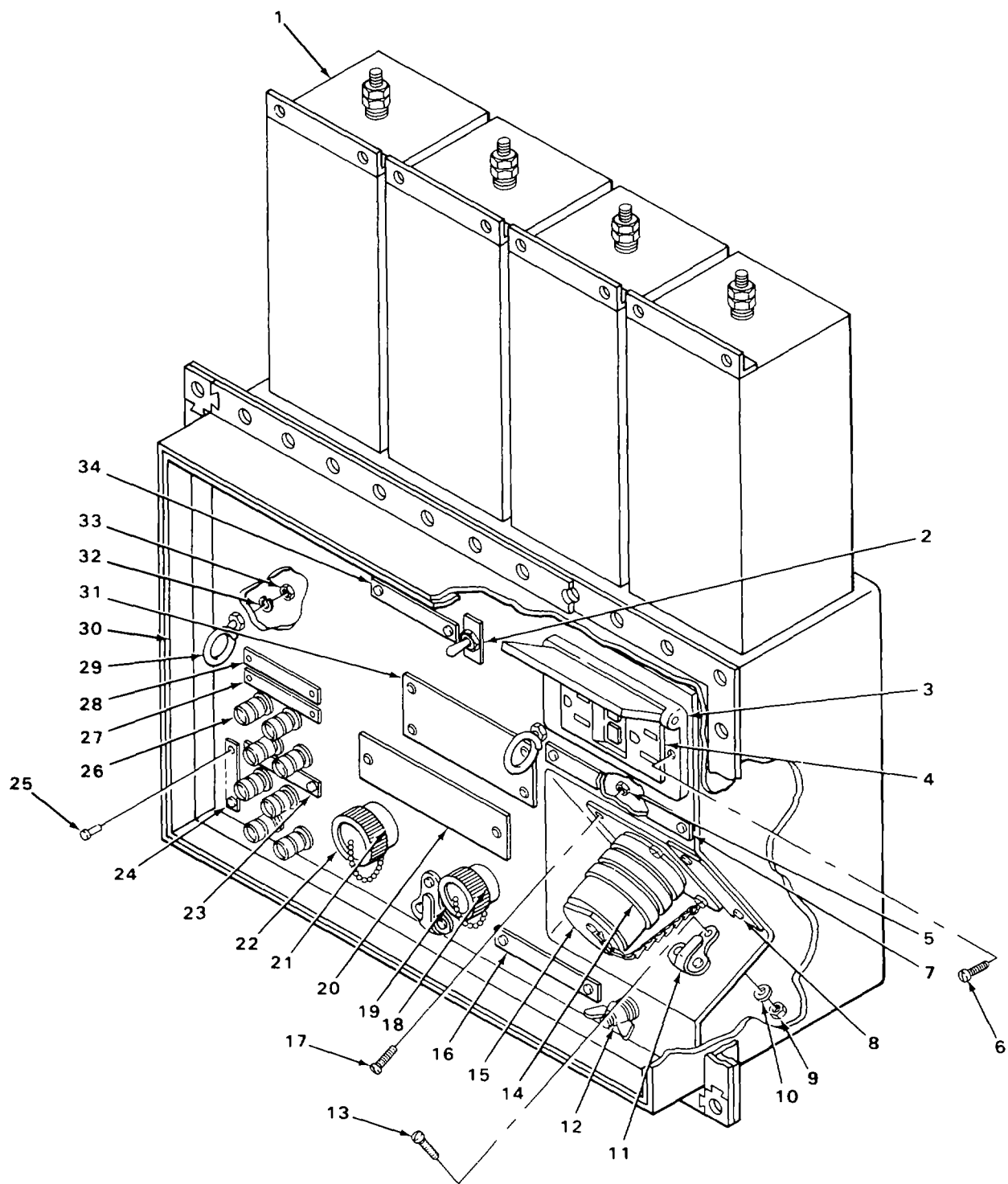

EL8YY019

FIGURE 7. POWER ENTRANCE BOX (208V-30) (SHEET 1 OF 2).  
33

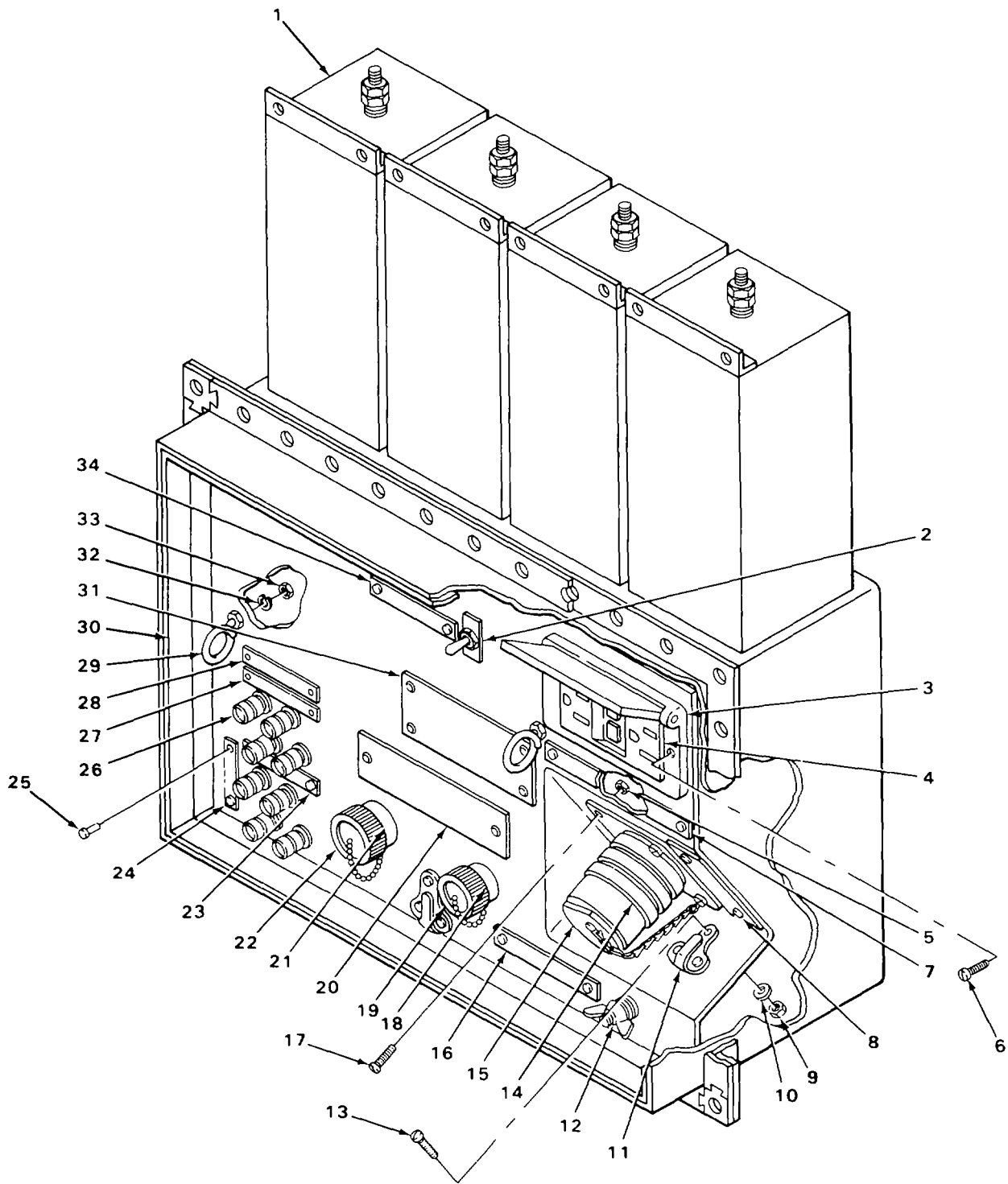

EL8YY019

FIGURE 7 POWER ENTRANCE BOX (208V-30) (SHEET 2 OF 2)

SECTION II

(1) ILLUSTRATION		(2)	(3)	(4)	(5)	(6)	(7)	(8)
(a) FIG NO.	(b) ITEM NO.	SMR CODE	NATIONAL STOCK NUMBER	FSCM	PART NUMBER	DESCRIPTION  USABLE ON CODE	U/M	QTY INC IN UNIT
						GROUP 01010102 POWER ENTRANCE BOX (208V-30)		
7	1	PAFZZ		56996	84029977	FILTER RFI .....	EA	4
7	2	PAFZZ		96906	M39019/1-258	CB MAG LOW PWR SLD .....	EA	1
7	3	XBFZZ		56996	84035461	WALL PL/CVR WITHPRF .....	EA	1
7	4	XBFZZ		56996	B4035462	RCPT DUPLEX GFI.....	EA	1
7	5	PAFZZ	5310-00-877-5797	96906	MS21044N3	NUT SELF LKG HEX .....	EA	4
7	6	PAFZZ	5305-00-054-6655	96906	MS51957-31	SCREW MACH PN HD.....	EA	2
7	7	XBFZZ		56996	84029713	PLATE,IDENT.....	EA	1
7	8	XBFZZ		56996	84029712	PLATE IDENT.....	EA	1
7	9	PAFZZ	5310-00-081-8087	96906	MS21044N06	NUT,SLF LKG HEX .....	EA	8
7	10	PAFZZ	5310-00-082-1404	96906	MS27183-6	WASHER,FL RND #6 .....	EA	8
7	11	XBFZZ		80063	SC-D-681226	HOOK,FENDER .....	EA	2
7	12	XBFZZ		80063	SC-C-539861	STUD ASSEMBLY.....	EA	1
7	13	PAFZZ	5305-00-719-5064	96906	MS51959-30	SCR MACH FL CSK HD .....	EA	6
7	14	PAFZZ	5935-00-114-8707	96906	MS90564-4C	CVR,ELECT CONNECTOR.....	EA	1
7	15	PAFZZ	5935-00-114-8708	96906	MS90558C32412P	CONN,RECPT,ELEC.....	EA	1
7	16	XBFZZ		80063	SC-B-543937	NAME PL,GRD TERM.....	EA	1
7	17	PAFZZ	5305-00-059-3663	96906	MS51958-67	SCREW MACHINE .....	EA	4
7	18	XBFFF		56996	84035457-1	CONN,ELEC 4 CNDCT.....	EA	1
7	19	PAFZZ		96906	MS27052B9N	CVR,PROT ELEC CONN.....	EA	1
7	20	XBFZZ		56996	84029870	IDENT PL (C-10333).....	EA	1
7	21	XBFFF		56996	84035457-2	CONN,ELEC.8 CNDCT.....	EA	1
7	22	PAFZZ		96906	MS207502B13N	CVR PROT ELECT CONN .....	EA	1
7	23	XBFZZ		80063	SC-B-627125	ID PL,PH INTERCOM.....	EA	1
7	24	XBFZZ		80063	SC-B-543941	NAME PL,BDG POST.....	EA	1
7	25	XBFZZ		80063	SC-C-539759-1	RVT,DOVE HD,GRIP .....	EA	24
7	26	PAFZZ	5940-00-937-5237	81349	PB08NA01	POST BINDING,EL.....	EA	8
7	27	XBFZZ		56996	B4029715	IDENT PL (SEND/RCV).....	EA	1
7	28	XBFZZ		56996	B4029716	IDENT PL .....	EA	1

SECTION II

TM 11-5411-211-24P/EE996-AA-PLL-010/E154 S639/TO 35E41 72-4-1

(1) ILLUSTRATION		(2)	(3)	(4)	(5)	(6)	(7)	(8)
(a) FIG NO.	(b) ITEM NO.	SMR CODE	NATIONAL STOCK NUMBER	FSCM	PART NUMBER	DESCRIPTION  USABLE ON CODE	U/M	QTY INC IN UNIT
7	29	PAFZZ		80063	SC-B-539608	RING BRIDLE.....	EA	2
7	30	XBFFF		56996	B4029868	FRAME AND BOX ASSY.....	EA	1
7	31	XBFFZ		56996	84029710	ID PL (208V-3).....	EA	1
7	32	PAFZZ	5310-00-582-5965	96906	MS35338-44	WASHER,LOCK SPR,t8.....	EA	20
7	33	PAFZZ	5310-00-834-8736	96906	MS35691-2	NUT PL HEX JAM.....	EA	2
7	34	XBFFZ		56996	B4029714	IDENT PLATE.....	EA	1
7	35	XBFFZ		80063	SC-C-68191	STUD ASSY 1/4-20.....	EA	2
7	36	XBFFZ		56996	B4029700	BRKT PWR ARRESTOR.....	EA	4
7	37	PAFZZ		09969	099695PA100	ARRESTOR,PWR.....	EA	4
7	38	PAFZZ		80063	SC-D-681420	FILTER,RFI TEL&INT.....	EA	8
7	39	PAFZZ	5305-00-984-6195	96906	MS35206-247	SCR,MACH PNH.....	EA	48
7	40	PAFZZ	5310-00-809-8544	96906	MS27183-7	WASHER,FL RND.....	EA	64
7	41	XBFFZ		56996	84029701	BAR,BUS.....	EA	4
7	42	PAFZZ	5305-00-984-6197	96906	MS35206-249	SCREW,MACH PNH.....	EA	4
7	43	XBFFZ		56996	84029702	BUS BAR,STANDOFF.....	EA	2
7	44	PAFZZ	5310-00-045-3299	96906	MS35338-42	WASHER,LOCK.....	EA	16
7	45	PAFZZ	5310-00-934-9757	96906	MS35649-282	NUT,PL HEX.....	EA	16
7	46	PAFZZ	5310-00-997-1888	96906	MS35649-2252	NUT,PL HEX.....	EA	16
7	47	PAFZZ	5310-00-809-4058	96906	MS27183-10	WASHER FL RND.....	EA	16

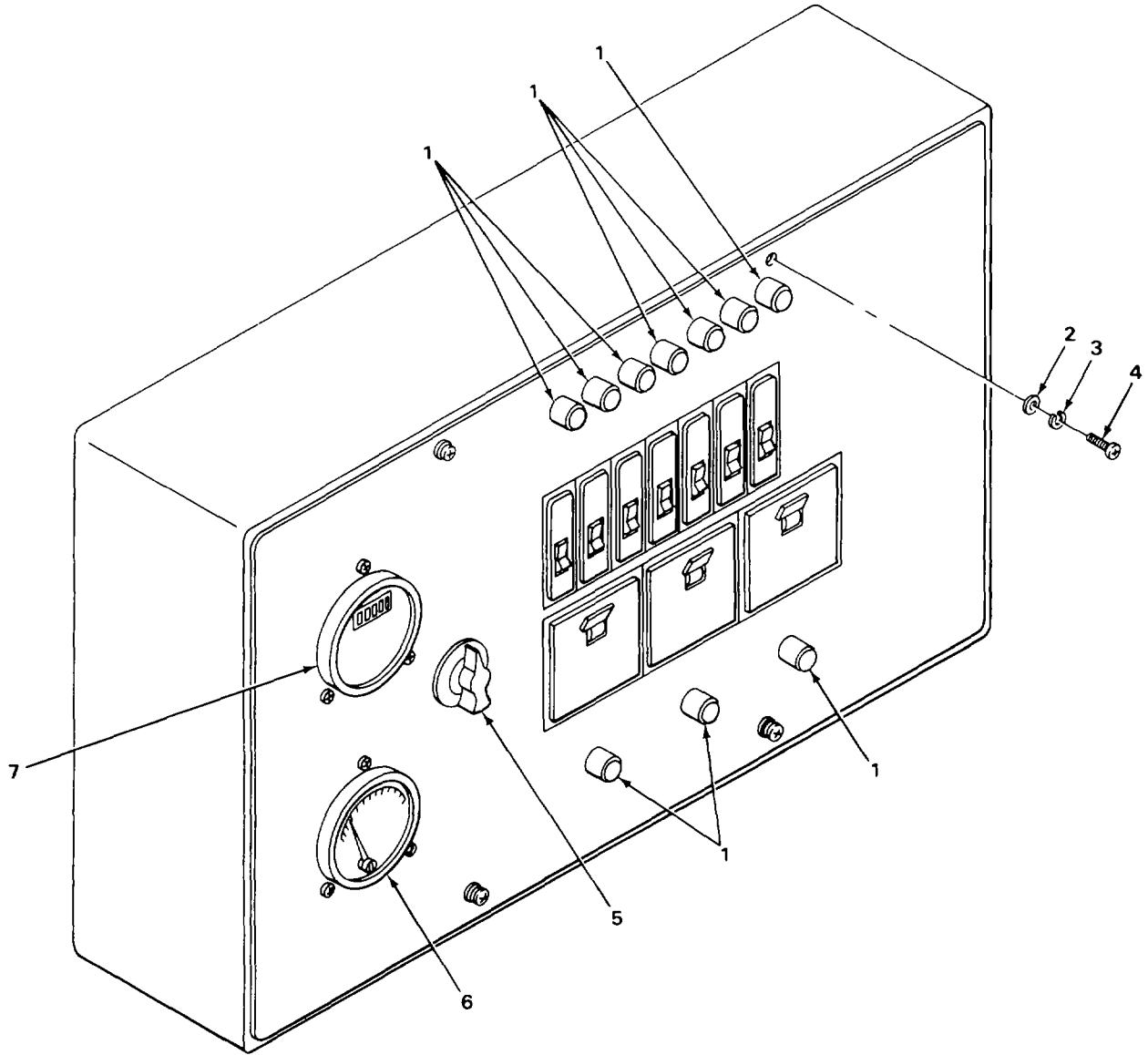

EL8YY037

FIGURE 8. POWER DISTRIBUTION BOX (208V-30) (SHEET 1 OF 2).



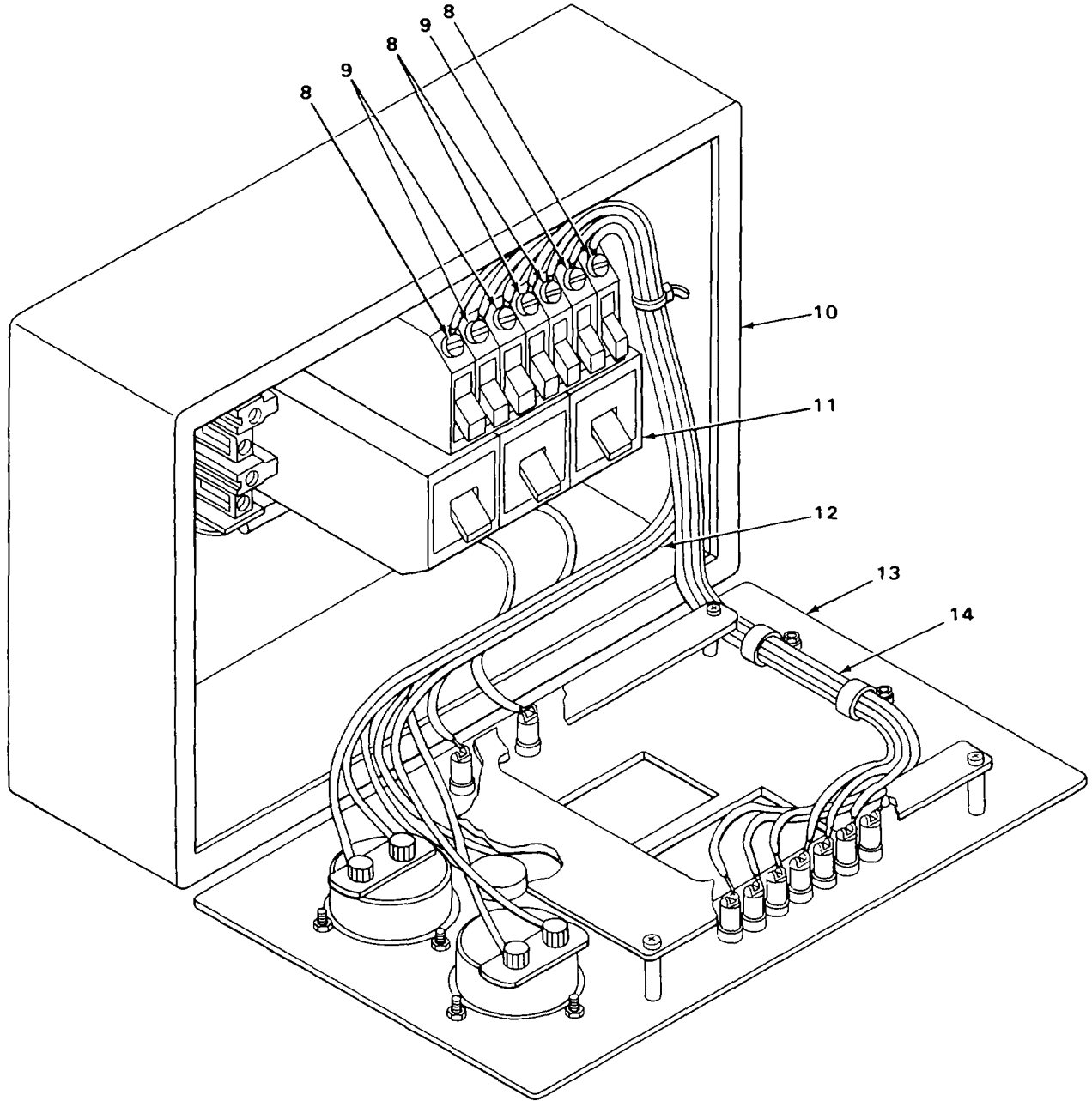

EL8YY038

FIGURE 8. POWER DISTRIBUTION BOX (208V-30) (SHEET 2 OF 2).

SECTION II

TM 11-5411-211-24P/EE996-AA-PLL-010/E154 S639/TO 35E41 72-4-1

(1) ILLUSTRATION		(2)	(3)	(4)	(5)	(6) DESCRIPTION	(7)	(8)
(a) FIG NO.	(b) ITEM NO.	SMR CODE	NATIONAL STOCK NUMBER	FSCM	PART NUMBER	USABLE ON CODE	U/M	QTY INC IN UNIT
						GROUP 01010103 POWER DISTRIBUTION BOX (208V-30)		
8	1	PAOZZ		56996	B4029871-2	LIGHT INDICATOR.....	EA	9
8	2	PAFZZ	5310-00-765-3197	96906	MS27183-41	WASHER FLAT .....	EA	9
8	3	PAFZZ	5310-00-045-3299	96906	MS35338-42	WASHER LOCK .....	EA	9
8	4	PAFZZ	5305-00-984-6195	96906	MS35206-247	SCREW PAN HD .....	EA	2
8	5	PAOZZ		81349	SR03NISB1MPO	SWITCH ROTARY.....	EA	1
8	6	PAOZZ	6625-00-643-3224	31356	34FHXX11	METER,FREQUENCY ELE .....	EA	1
8	7	PAOZZ	6625-00-341-4071	81349	MR36WISOACVVR	VOLTMETER.....	EA	1
8	8	PAFZZ	5925-01-042-0109	81348	WC375/01-002	CIRCUIT BREAKER .....	EA	4
8	9	PAFZZ	5925-01-111-7562	81348	WC375/01-003	CIRCUIT BREAKER .....	EA	3
8	10	XBFZZ		56996	B4029862	LOAD CNTR ASSY.....	EA	1
8	11	PAFZZ	5925-01-161-3800	80063	SC-C-916339	CIRCUIT BREAKER .....	EA	3
8	12	XBFZZ		56996	84029863	HARNESS WIRE .....	EA	1
8	13	XBFZZ		56996	B4029857	FRONT CVR ASSY .....	EA	1
8	14	XBFZZ		56996	B4029864	HARNESS,WIRE .....	EA	1

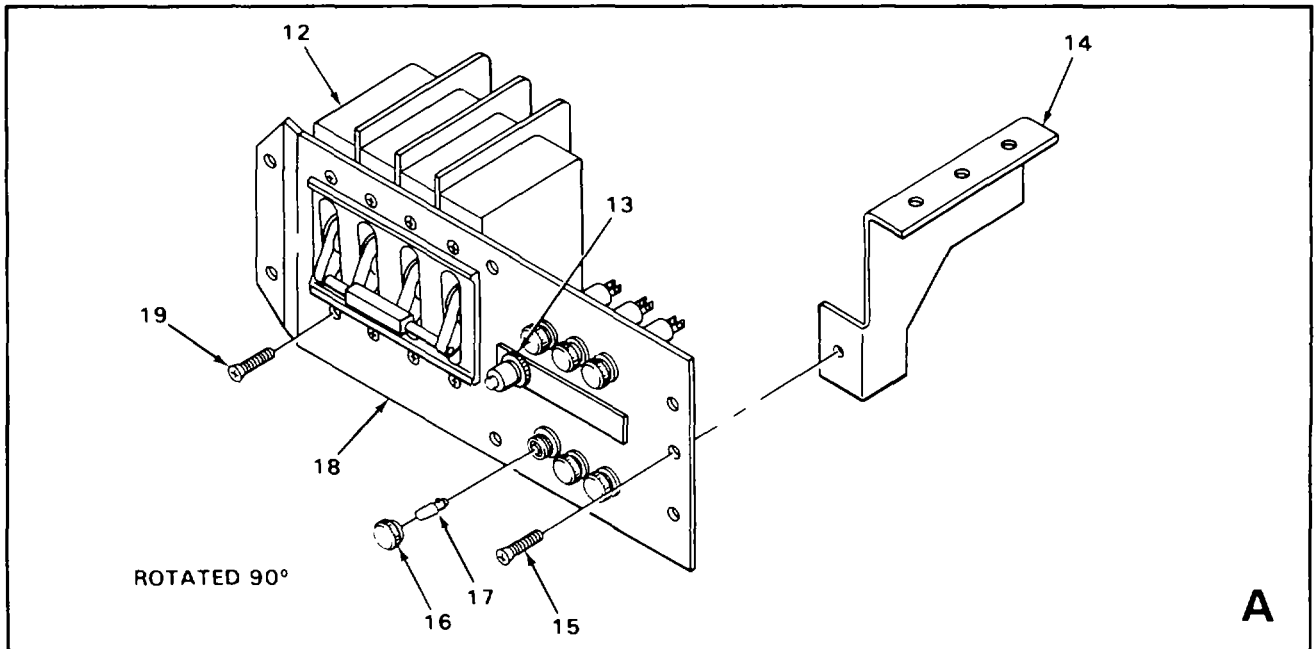
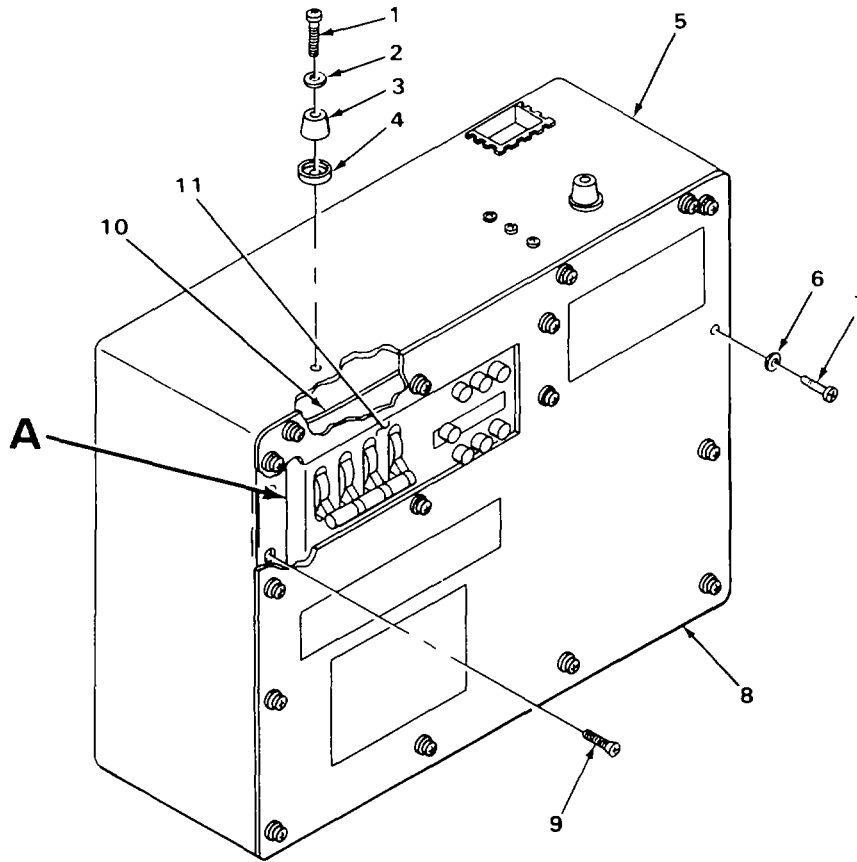

ELBY021

FIGURE 9. MAIN LINE POWER FILTER BOX

SECTION II

TM 11-5411-211-24P/EE996-AA-PLL-010/E154 S639/TO 35E41 72-4-1

(1) ILLUSTRATION		(2)	(3)	(4)	(5)	(6) DESCRIPTION	(7)	(8)
(a) FIG NO.	(b) ITEM NO.	SMR CODE	NATIONAL STOCK NUMBER	FSCM	PART NUMBER	USABLE ON CODE	U/M	QTY INC IN UNIT
						GROUP 01010104 MAIN LINE POWER FILTER BOX		
9	1	PAOZZ	5305-00-054-6654	96906	MS51957-30	SCREW PAN HD.....	EA	2
9	2	PAOZZ	5310-00-722-5998	96906	MS15795-805	WASHER FLAT ID 156.....	EA	2
9	3	XBOZZ		80063	SC-C-947747	STOPPER RUBBER.....	EA	2
9	4	XBOZZ		80063	SC-C-916251	SPACER.....	EA	2
9	5	XBOZZ		56996	B4029972	FRAME MOUNTING.....	EA	1
9	6	PAOZZ	5310-00-595-6772	95542	2038-8009	WASHER FLAT ID 219.....	EA	23
9	7	PAOZZ	5305-00-059-3659	96906	MS51958-63	SCREW PAN HD.....	EA	23
9	8	XBOZZ		56996	B4029973	COVER.....	EA	1
9	9	PAOZZ	5305-00-071-1322	96906	MS51960-65	SCREW FLAT HD.....	EA	2
9	10	XBOZZ		56996	B4029970	BRKT ASSY.....	EA	1
9	11	XBOZZ		74193	CD4A3-70-240-1	MAIN PWR CKT BRKR.....	EA	1
9	12	PAOZZ		80063	SC-C-947726	CIRCUIT BREAKER.....	EA	1
9	13	XBOZZ		56996	B4029976-5	PHASE INDICATOR LT.....	EA	1
9	14	XBOZZ		56996	84035268	BRACKET PNL.....	EA	1
9	15	PAOZZ		96906	MS51960-65	SCREW CSK.....	EA	6
9	16	XBOZZ		56996	B4029871-2	INDICATOR LIGHT.....	EA	6
9	17	XBOZZ		56996	84029873-18	BULB T 3 1/4.....	EA	1
9	18	XBOZZ		56996	B4035267	PNL CKT BRK.....	EA	1
9	19	PAOZZ		96906	MS51959-28	SCREW CSK.....	EA	8

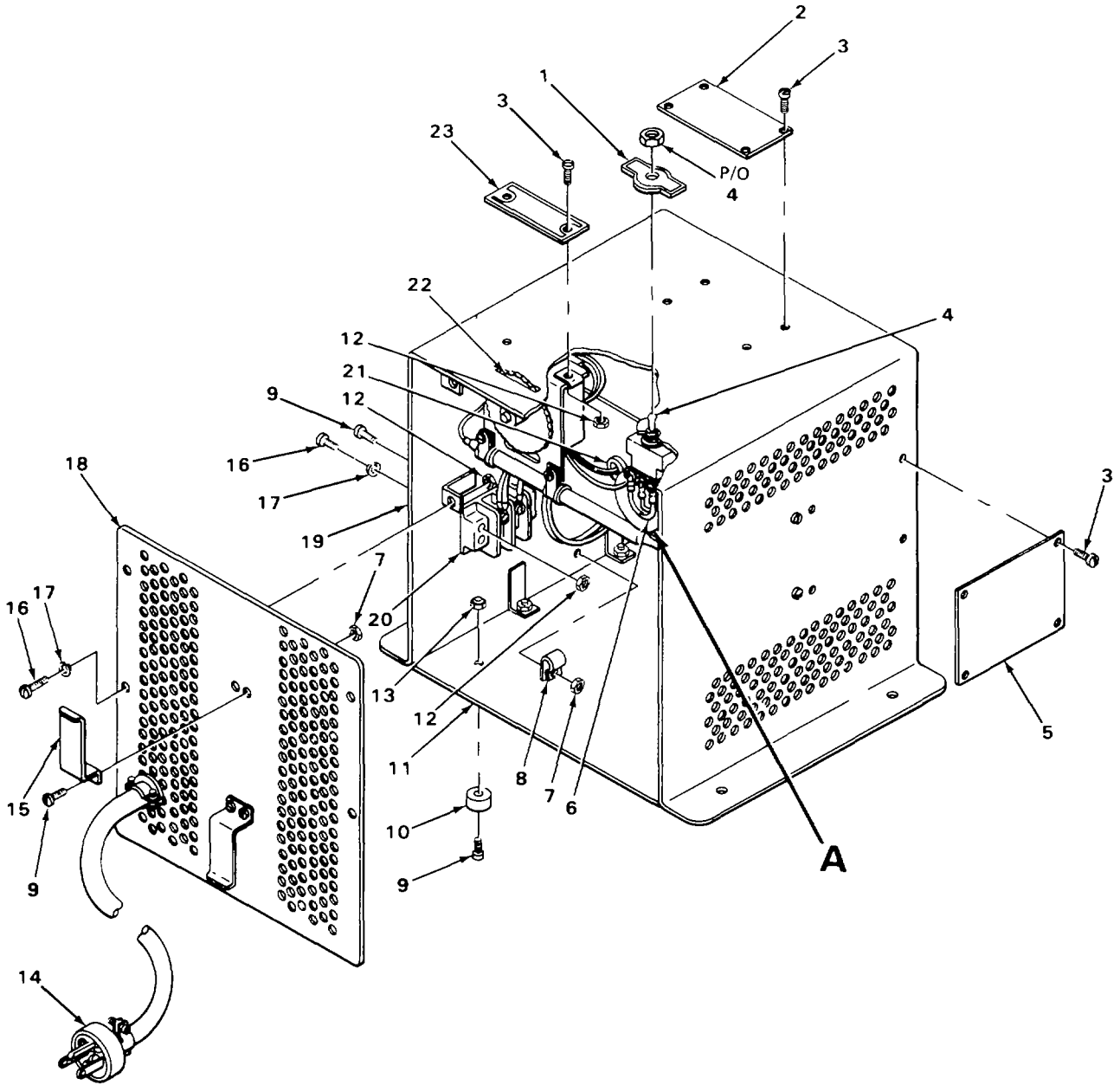

EL8YY022

FIGURE 10. HEATER (SHEET 1 OF 2)

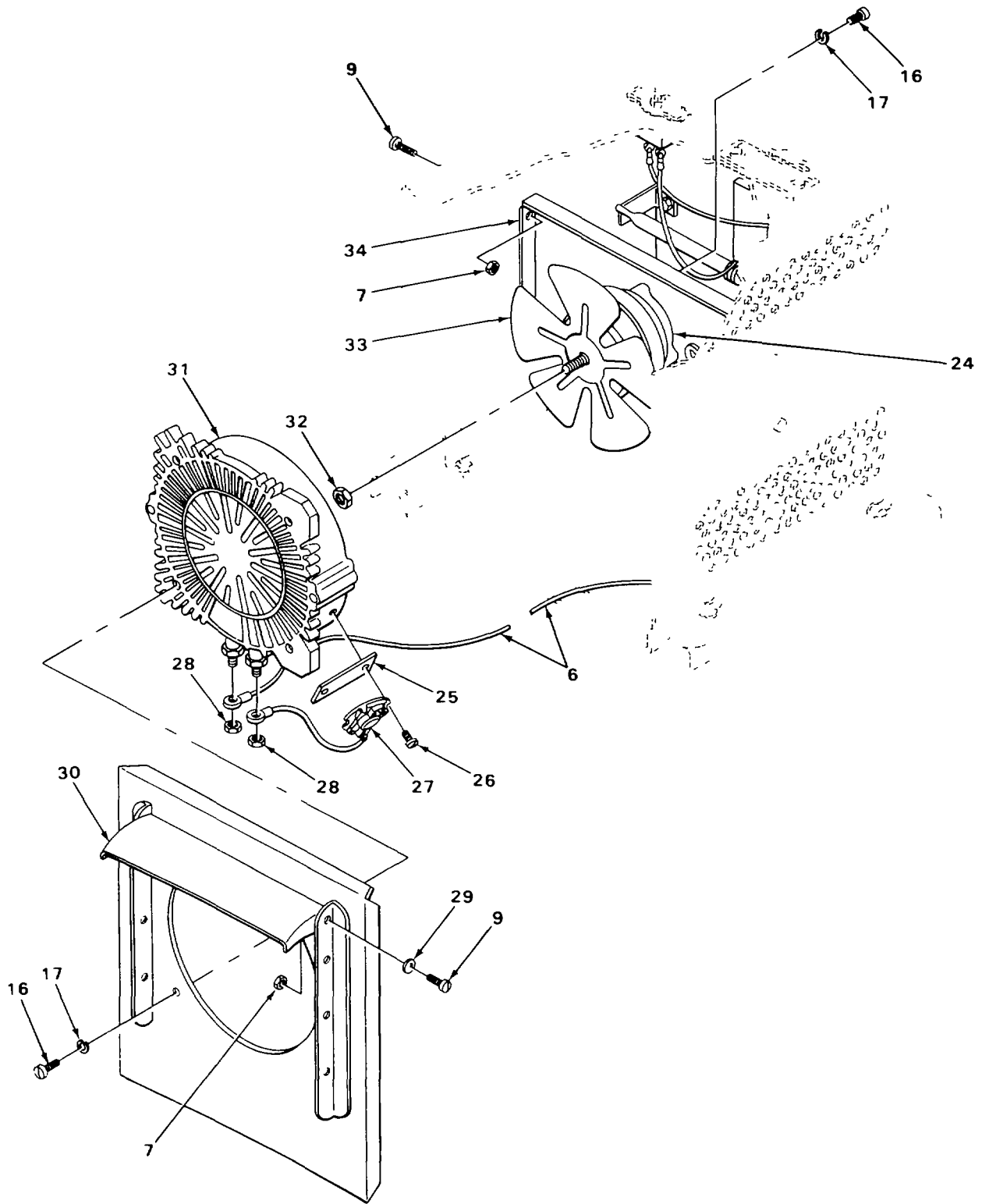

FIGURE 10. HEATER (SHEET 2 OF 2)

EL8YY023

SECTION II

(1) ILLUSTRATION		(2)	(3)	(4)	(5)	(6) DESCRIPTION	(7)	(8)
(a) FIG NO.	(b) ITEM NO.	SMR CODE	NATIONAL STOCK NUMBER	FSCM	PART NUMBER	USABLE ON CODE	U/M	QTY INC IN UNIT
						GROUP 03 HEATER		
10	1	XBFZZ		80063	SC-B-539646	PLATE IDENT.....	EA	1
10	2	XBFZZ		80063	SC-B-539792	PLATE INFORMATION .....	EA	1
10	3	PAFZZ	5305-00-855-0968	96906	MS24629-10	SCREW TAPPING.....	EA	10
10	4	PAFZZ	5930-00-702-6431	96906	MS25307-212	SWITCH TOGGLE.....	EA	1
10	5	XBFZZ		80063	SC-B-539873	PLATE,WIRING DIAG .....	EA	1
10	6	XBFZZ		80063	SC-B-539657	WIRE ASSEMBLY .....	EA	2
10	7	XBFZZ		96906	MS35690-9	NUT PLAIN HEXAGON .....	EA	21
10	8	PAFZZ	5340-00-664-3092	96906	MS9024-03	CLAMP LOOP .....	EA	3
10	9	PAFZZ	5305-00-543-4302	96906	MS35265-79	SCREW MACHINE .....	EA	21
10	10	PAFZZ	5970-01-050-4203	80063	SC-B-681042	INSULATOR,WASHER.....	EA	1
10	11	XBFZZ		80063	SC-B-539645	PLATE BOTTOM .....	EA	1
10	12	PAFZZ	5310-00-811-3494	96906	MS21044N08	NUT,SELF-LOCKING .....	EA	3
10	13	PAFZZ	5310-00-087-4652	96906	MS51922-17	NUT,SELF-LOCKING .....	EA	1
10	14	XBFZZ		80063	SC-C-539906	CABLE ASSY HEATER .....	EA	1
10	15	XBFZZ		80063	SC-B-539653	BRACKET .....	EA	2
10	16	PAFZZ	5305-00-660-2467	96906	MS35265-80	SCREW,MACHINE .....	EA	16
10	17	PAFZZ	5310-00-045-3299	96906	MS35338-42	WASHER,LOCK .....	EA	16
10	18	XBFZZ		80063	SC-C-539665	PANEL ASSY,REAR .....	EA	1
10	19	XBFZZ		80063	SC-D-539660	CASE,WELDED ASSY .....	EA	1
10	20	XBFZZ		80063	SC-D-539901-5	TERMINAL STRIP .....	EA	1
10	21	PAFZZ	5325-00-291-9366	96906	MS35489-11	GROMMET,NONMETALLIC.....	EA	1
10	22	XBFZZ		80063	SC-D-539652	THERMOSTAT .....	EA	1
10	23	XBFZZ		80063	SC-B-539654	PLATE IDENT.....	EA	1
10	24	XBFZZ		80063	SC-C-539650	MOTOR .....	EA	1
10	25	XBFZZ		80063	SC-B-681206	PLATE .....	EA	1
10	26	PAFZZ	5305-00-781-7244	96906	MS35265-78	SCREW MACHINE .....	EA	2
10	27	PAFZZ	5930-00-197-4295	17032	23T21	SWITCH,THERMOSTAT .....	EA	1
10	28	PAFZZ	5310-00-934-9747	96906	MS35649-262	NUT,PLAIN,HEXAGON .....	EA	2

SECTION II

TM 11-5411-211-24P/EE996-AA-PLL-010/E154 S639/TO 35E41 72-4-1

(1) ILLUSTRATION		(2)	(3)	(4)	(5)	(6) DESCRIPTION	(7)	(8)
(a) FIG NO.	(b) ITEM NO.	SMR CODE	NATIONAL STOCK NUMBER	FSCM	PART NUMBER	USABLE ON CODE	U/M	QTY INC IN UNIT
10	29	PAFZZ	5310-00-809-8546	96906	MS27183-8	WASHER FLAT .....	EA	8
10	30	XBFZZ		80063	SC-B-539645-1	LOUVER .....	EA	4
10	31	PAFZZ	4540-00-404-9232	26916	21C043-0	HEATER ELEMENT .....	EA	1
10	32	PAFZZ	5310-00-997-1888	96906	MS35649-2252	NUT PLAIN HEXAGON .....	EA	1
10	33	PAFZZ	4140-00-765-7748	60399	MSA3847-1	FAN .....	EA	1
10	34	XBFZZ		80063	SC-C-539648	PLATE MOTOR MTG .....	EA	2



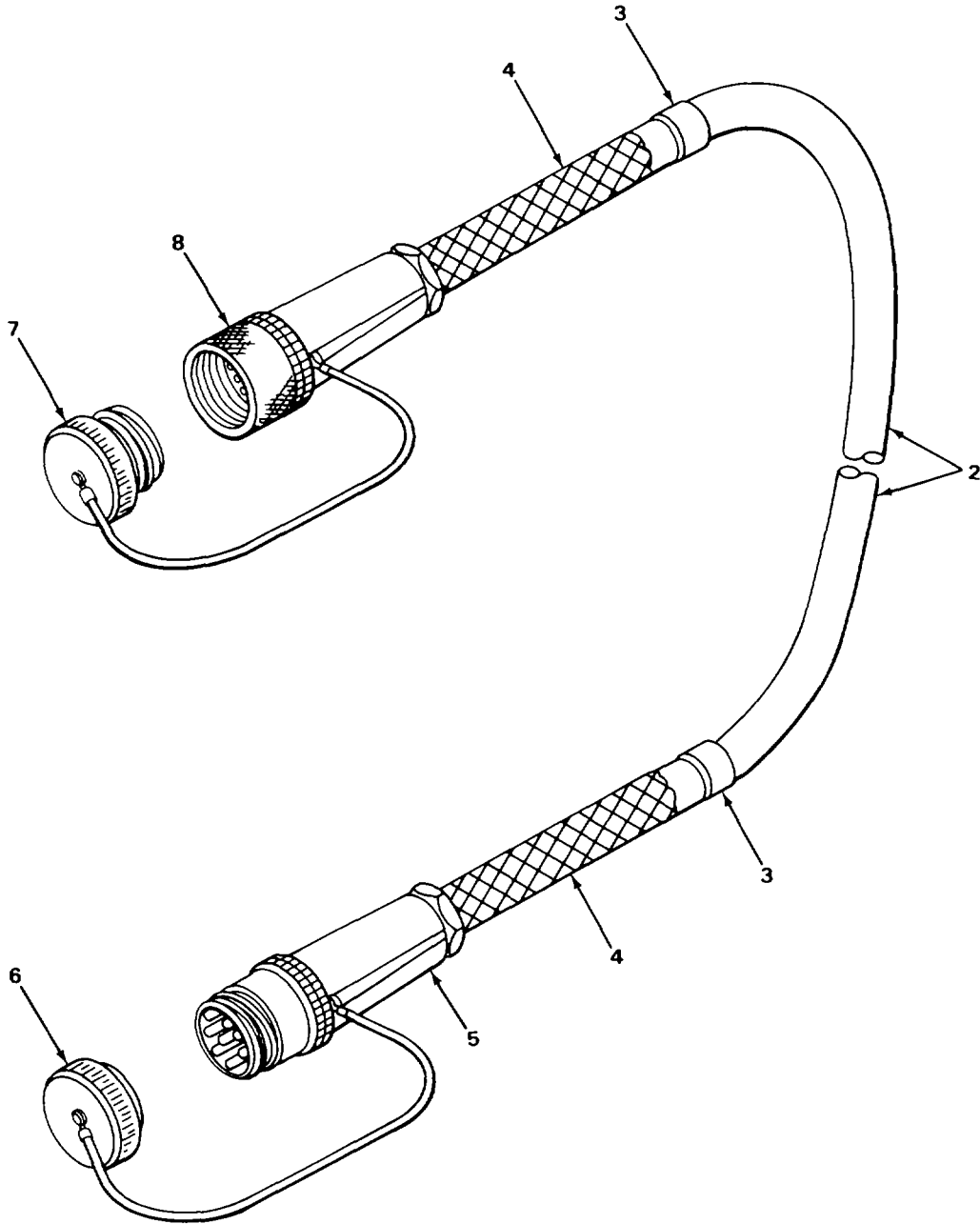
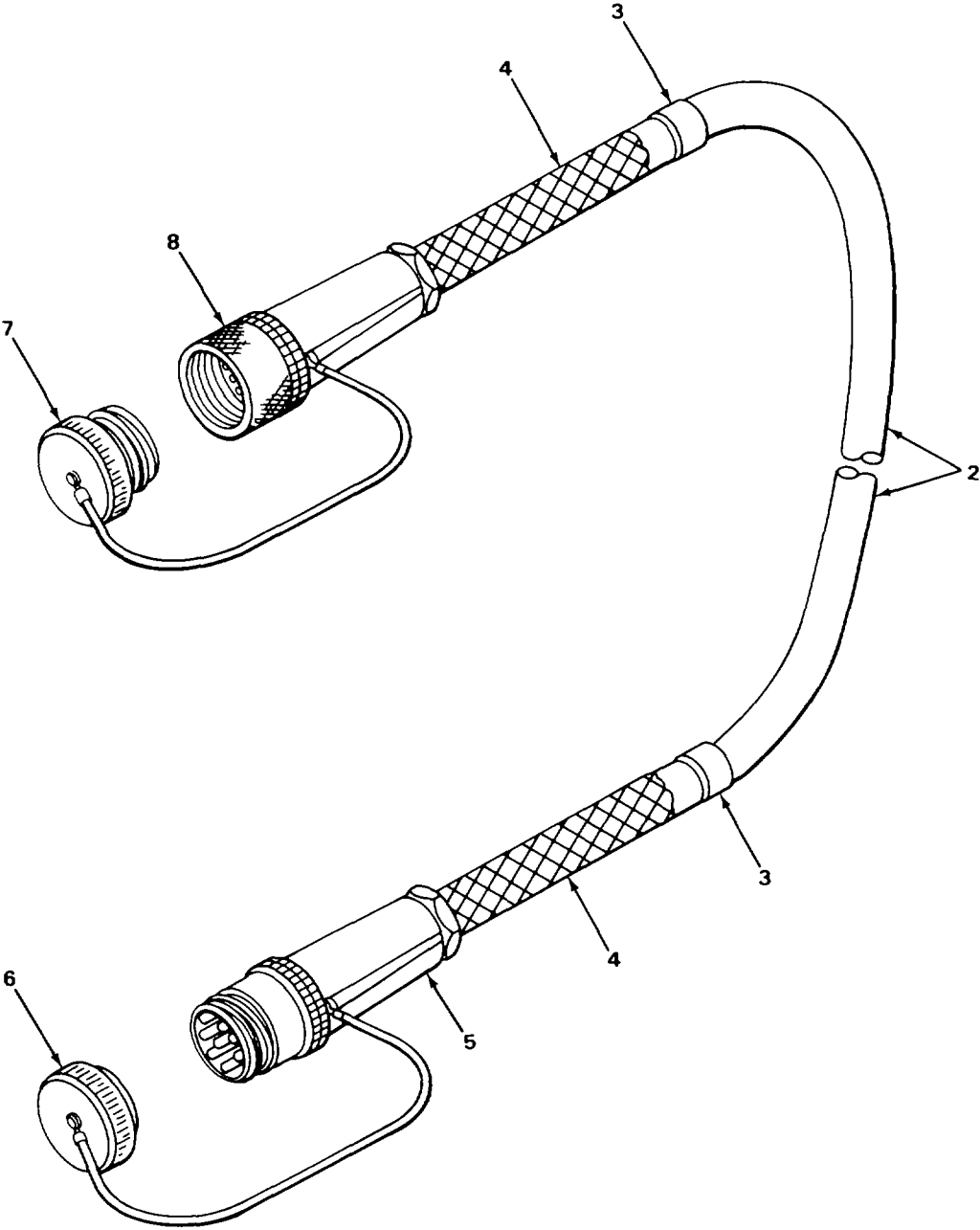

FIGURE 11. POWER CABLES (SHEET 1 OF 2)

EL8YY025



ELBYY025

FIGURE 11. POWER CABLES (SHEET 2 OF 2)

SECTION II

TM 11-5411-211-24P/EE996-AA-PLL-010/E154 S639/TO 35E41 72-4-1

(1) ILLUSTRATION		(2)	(3)	(4)	(5)	(6) DESCRIPTION	(7)	(8)
(a) FIG NO.	(b) ITEM NO.	SMR CODE	NATIONAL STOCK NUMBER	FSCM	PART NUMBER	USABLE ON CODE	U/M	QTY INC IN UNIT
						GROUP 06 POWER CABLES		
11	1	XBFZZ		80063	SC-D-883964-7	SEAL END .....	EA	1
11	2	XBFZZ		96906	CO-04HD(4/6-4/12 R)1090	CABLE .....	EA	2
11	3	XBFZZ		81349	MIL-P-15024/8TYP EK2	BAND IDENT .....	EA	2
11	4	PAFZZ	5935-01-085-6599	96906	MS90561-2	GRP,CBL WVN,STRNRLF .....	EA	2
11	5	PAFZZ		96906	MS90557C32512S	CONNECTOR PLUG .....	EA	2
11	6	PAFZZ	5935-00-114-7285	96906	MS90563-4C	CVR ELE CONN RCPT .....	EA	2
11	7	PAFZZ	5935-00-114-8707	96906	MS90564-4C	CVR ELE CONN,RCPT .....	EA	1
11	8	PAFZZ		96906	MS90556C32512S	CONNECTOR,PLUG .....	EA	1

## SECTION IV

TM 11-5411-211-24P/EE996-AA-PLL-010/E154 S639/TO 35E41 72-4-1  
**CROSS- REFERENCE-INDEXES**  
**NATIONAL STOCK NUMBER INDEX**

STOCK NUMBER	FIG.	ITEM	STOCK NUMBER	FIG.	ITEM
5310-00-014-5850	3	7	5310-00-722-5998	9	2
5305-00-015-0964	3	15	5310-00-765-3197	8	2
5930-00-027-2313	5	13	4140-00-765-7748	10	33
5310-00-045-3296	1	34	5305-00-781-5654	3	4
5310-00-045-3296	3	6	5305-00-781-7244	10	26
5310-00-045-3299	7	44	5310-00-809-4058	7	47
5310-00-045-3299	8	3	5310-00-809-4058	1	31
5310-00-045-3299	4	17	5310-00-809-4058	2	16
5310-00-045-3299	10	17	5310-00-809-4058	3	32
5305-00-054-6654	9	1	5310-00-809-8544	7	40
5305-00-054-6655	7	6	5310-00-809-8544	2	11
5305-00-054-6670	2	8	5310-00-809-8544	4	45
5305-00-059-3659	9	7	5310-00-809-8546	10	29
5305-00-059-3663	7	17	5310-00-811-3494	2	12
5305-00-068-0501	2	44	5310-00-811-3494	10	12
5305-00-068-0501	3	36	5310-00-829-9981	2	36
5305-00-068-0508	1	33	5310-00-829-9981	3	27
5305-00-071-1322	9	9	5310-00-834-8736	7	33
5305-00-071-2510	2	15	5305-00-855-0968	10	3
5310-00-081-4219	1	44	5310-00-877-5797	7	5
5310-00-081-4219	2	34	5305-00-889-3000	3	12
5310-00-081-4219	3	29	5310-00-934-9747	3	11
5310-00-081-8087	7	9	5310-00-934-9747	10	28
5310-00-082-1404	7	10	5310-00-934-9757	7	45
5305-00-087-0259	1	35	5310-00-934-9757	4	18
5310-00-087-4652	10	13	5940-00-937-5237	7	26
5935-00-114-7285	11	6	5305-00-958-5247	2	21
5935-00-114-8707	7	14	5305-00-958-5477	2	29
5935-00-114-8707	11	7	5310-00-974-6623	2	6
5935-00-114-8708	7	15	5310-00-982-6814	4	44
4520-00-117-6198	1	41	5310-00-984-3806	2	18
5930-00-197-4295	10	27	5305-00-984-4982	4	23
5975-00-224-5260	1	21	5305-00-984-6191	4	21
5305-00-225-3839	2	25	5305-00-984-6195	7	39
5305-00-225-8476	2	38	5305-00-984-6195	8	4
5306-00-225-8495	1	42	5305-00-984-6195	4	48
5306-00-225-8497	2	7	5305-00-984-6197	7	42
5305-00-225-9081	2	32	5305-00-988-1727	2	31
5305-00-225-9081	3	19	5305-00-989-7434	3	5
7520-00-281-5911	1	17	5310-00-997-1888	7	46
5935-00-283-4003	4	25	5310-00-997-1888	2	40
5325-00-291-9366	10	21	5310-00-997-1888	3	25
6625-00-341-4071	8	7	5310-00-997-1888	10	32
4540-00-404-9232	10	31	5830-01-008-3126	1	15
5310-00-407-9566	1	43	5935-01-016-3638	4	3
5310-00-407-9566	2	33	5340-01-023-0504	3	10
5310-00-407-9566	3	18	5935-01-024-4028	4	5
5305-00-543-4302	10	9	5935-01-036-5170	4	8
5310-00-582-5965	7	32	5925-01-042-0109	8	8
5310-00-582-5965	1	32	5970-01-050-4203	10	10
5310-00-582-5965	2	26	5855-01-072-9865	2	24
5310-00-582-5965	3	31	5935-01-085-6599	11	4
5310-00-595-6057	2	5	5340-01-094-5434	3	3
5310-00-595-6772	9	6	5925-01-111-7562	8	9
6625-00-643-3224	8	6	5925-01-161-3800	8	11
5305-00-660-2467	10	16	5340-01-169-2882	3	8
5340-00-664-3092	10	8	5340-01-184-6394	4	47
5930-00-702-6431	10	4	5340-01-184-6404	4	46
5305-00-719-5064	7	13			
5310-00-720-8549	3	9			

## SECTION IV

## TM 11-5411-211-24P/EE996-AA-PLL-010/E154 S639/TO 35E41 72-4-1

## NATIONAL STOCK NUMBER AND PART NUMBER INDEX

NATIONAL STOCK NUMBER			FIG.	ITEM	NATIONAL STOCK NUMBER			FIG.	ITEM
58536	A-A-182	7520-00-281-5911	1	17	56996	B4029826-3	5	7	
91929	BZ-2RQ18T	5930-00-027-2313	5	13	56996	B4029826-4	6	9	
56996	B4029657		1	5	56996	B4029842	1	2	
56996	B4029658		2	1	56996	B4029857	8	13	
56996	B4029659		4	49	56996	B4029862	8	10	
56996	B4029660		6	7	56996	B4029863	8	12	
56996	B4029669		2	35	56996	B4029864	8	14	
56996	B4029676		1	12	56996	B4029868	7	30	
56996	B4029677		2	42	56996	B4029870	7	20	
56996	B4029685		1	40	56996	B4029871-2	8	1	
56996	B4029687		3	35	56996	B4029871-2	9	16	
56996	B4029688		5	8	56996	B4029873-18	9	17	
56996	B4029689		5	9	56996	B4029898	5	4	
56996	B4029690		6	2	56996	B4029970	9	10	
56996	B4029691		5	5	56996	B4029972	9	5	
56996	B4029700		7	36	56996	B4029973	9	8	
56996	B4029701		7	41	56996	B4029976-5	9	13	
56996	B4029702		7	43	56996	B4029977	7	1	
56996	B4029710		7	31	56996	B4030004-1	4	43	
56996	B4029712		7	8	56996	B4030004-2	4	1	
56996	B4029713		7	7	56996	B4035200	3	23	
56996	B4029714		7	34	56996	B4035207	5	3	
56996	B4029715		7	27	56996	B4035222-1	4	42	
56996	B4029716		7	28	56996	B4035222-2	4	6	
56996	B4029719		1	24	56996	B4035235	1	19	
56996	B4029730		1	11	56996	B4035243	4	19	
56996	B4029733		4	40	56996	B4035267	9	18	
56996	B4029734		3	28	56996	B4035268	9	1a	
56996	B4029736		3	24	56996	B4035270	6	5	
56996	B4029738		3	30	56996	B4035272	6	6	
56996	B4029739		3	33	56996	B4035288	4	28	
56996	B4029747		1	6	56996	B4035291	4	31	
56996	B4029761-1		4	2	56996	B4035292-2	4	32	
56996	B4029761-2		4	4	56996	B4035317-001	6	15	
56996	B4029761-3		4	26	56996	B4035457-1	7	18	
56996	B4029763-1		4	11	56996	B4035457-2	7	21	
56996	B4029763-2		4	12	56996	B4035461	7	3	
56996	B4029763-3		4	16	56996	B4035462	7	4	
56996	B4029763-4		4	15	56996	B403592-1	4	33	
56996	B4029764-1		4	7	74193	CD4A3-70-240-1	9	11	
56996	B4029764-2		4	13	96906	CO-04HD(4/6-4/12	11	2	
56996	B4029764-3		4	14	R)1090				
56996	B4029766-1		4	39	80058	LS-147F/F1	5830-01-008-3126	1	15
56996	B4029766-2		4	36	81349	MIL-P-150248TYP		11	3
56996	B4029779		3	34		EK2			
56996	B4029793-2		4	30	81349	MILH52641	4520-00-117-6198	1	41
56996	B4029794		4	38	81349	MR36W150ACVVR	6625-00-341-4071	8	7
56996	B4029800		4	9	60399	MSA3847-1	4140-00-765-7748	10	33
56996	B4029802		2	10	96906	MS15795-805	5310-00-722-5998	9	2
56996	B4029803		2	13	96906	MS15795-815	5310-00-595-6057	2	5
56996	B4029811		2	4	96906	MS207502813N		7	22
56996	B4029812		1	3	96906	MS21044C08	5310-00-982-6814	4	44
56996	B4029812		2	17	96906	MS21044N06	5310-00-081-8087	7	9
56996	B4029813		2	2	96906	MS21044N08	5310-00-811-3494	2	12
56996	B4029816		4	27	96906	MS21044N08	5310-00-811-3494	10	12
56996	B4029817		2	37	96906	MS21044N3	5310-00-877-5797	7	5
56996	B4029818		2	39	96906	MS24629-10	5305-00-855-0968	10	3
56996	B4029819		3	1	96906	MS24692-S144	5305-00-225-8476	2	38
56996	B4029822-1		6	10	96906	MS24693S97	5305-00-781-5654	3	4
56996	B4029822-2		5	6	96906	MS25307-212	5930-00-702-6431	10	4

## SECTION IV

TM 11-5411-211-24P/EE996-AA-PLL-010/E154 S639/TO 35E41 72-4-1  
 NATIONAL STOCK NUMBER AND PART NUMBER INDEX

NATIONAL STOCK NUMBER				NATIONAL STOCK NUMBER					
		FIG.	ITEM			FIG.	ITEM		
96906	MS2705289N		7	19	96906	MS51922-9	5310-00-984-3806	2	18
96906	MS27183-10	5310-00-809-4058	7	47	96906	MS51957-30	5305-00-054-6654	9	1
96906	MS27183-10	5310-00-809-4058	1	31	96906	MS51957-31	5305-00-054-6655	7	6
96906	MS27183-10	5310-00-809-4058	2	16	96906	MS51957-45	5305-00-054-6670	2	8
96906	MS27183-10	5310-00-809-4058	3	32	96906	MS51958-63	5305-00-059-3659	9	7
96906	MS27183-12	5310-00-081-4219	1	44	96906	MS51958-67	5305-00-059-3663	7	17
96906	MS27183-12	5310-00-081-4219	2	34	96906	MS51959-28		9	19
96906	MS27183-12	5310-00-081-4219	3	29	96906	MS51959-30	5305-00-719-5064	7	13
96906	MS27183-41	5310-00-765-3197	8	2	96906	MS51960-65	5305-00-071-1322	9	9
96906	MS27183-42	5310-00-014-5850	3	7	96906	MS51960-65		9	15
96906	MS27183-6	5310-00-082-1404	7	10	96906	MS9024-03	5340-00-664-3092	10	8
96906	MS27183-7	5310-00-809-8544	7	40	96906	MS90566C32512S		11	8
96906	MS27183-7	5310-00-809-8544	2	11	96906	MS90557C32512S		11	5
96906	MS27183-7	5310-00-809-8544	4	45	96906	MS90558C32412P	5935-00-114-8708	7	15
96906	MS27183-8	5310-00-809-8546	10	29	96906	MS90561-2	5935-01-085-6599	11	4
96906	MS35190-254	5305-00-958-5477	2	29	96906	MS90563-4C	5935-00-114-7285	11	6
96906	MS35190-291	5305-00-958-5247	2	21	96906	MS90564-4C	5935-00-114-8707	7	14
96906	MS35206-225	5305-00-984-4982	4	23	96906	MS90564-4C	5935-00-114-8707	11	7
96906	MS35206-230	5305-00-889-3000	3	12	96906	MS90725-30	5306-00-225-8495	1	42
96906	MS35206-243	5305-00-984-6191	4	21	96906	MS90725-32	5306-00-225-8497	2	7
96906	MS35206-247	5305-00-984-6195	7	39	96906	MS90725-36	5305-00-225-9081	2	32
96906	MS35206-247	5305-00-984-6195	8	4	96906	MS90725-36	5305-00-225-9081	3	19
96906	MS35206-247	5305-00-984-6195	4	48	96906	MS90725-5	5305-00-068-0501	2	44
96906	MS35206-249	5305-00-984-6197	7	42	96906	MS90725-5	5305-00-068-0501	3	36
96906	MS35206-283	5305-00-988-1727	2	31	96906	MS90725-8	5305-00-225-3839	2	25
96906	MS35207-263	5305-00-989-7434	3	5	96906	MS90728-13	5305-00-071-2510	2	15
96906	MS35265-78	5305-00-781-7244	10	26	96906	MS90728-6	5305-00-068-0508	1	33
96906	MS35265-79	5305-00-543-4302	10	9	96906	MS9122-05	5305-00-087-0259	1	35
96906	MS35265-80	5305-00-660-2467	10	16	80063	MX-148/G	5975-00-224-5260	1	21
96906	MS35338-140	5310-00-974-6623	2	6	96906	M39019/1-258		7	2
96906	MS35338-42	5310-00-045-3299	7	44		NPN		2	3
96906	MS35338-42	5310-00-045-3299	8	3		NPN		2	14
96906	MS35338-42	5310-00-045-3299	4	17		NPN		2	22
96906	MS35338-42	5310-00-045-3299	10	17		NPN		2	23
96906	MS35338-43	5310-00-045-3296	1	34		NPN		3	20
96906	MS35338-43	5310-00-045-3296	3	6		NPN		3	21
96906	MS35338-44	5310-00-582-5965	7	32		NPN		3	22
96906	MS35338-44	5310-00-582-5965	1	32	81349	PB08NA01	5940-00-937-5237	7	26
96906	MS35338-44	5310-00-582-5965	2	26	81348	PP-4763A/GRC		1	23
96906	MS35338-44	5310-00-582-5965	3	31	56996	S-639/G		1	1
96906	MS35338-45	5310-00-407-9566	1	43	80063	SC-8-539420	5340-01-023-0504	3	10
96906	MS35338-45	5310-00-407-9566	2	33	80063	SC-B-539439-1		3	14
96906	MS35338-45	5310-00-407-9566	3	18	80063	SC-B-539474		3	13
96906	MS35426-13	5310-00-720-8549	3	9	80063	SC-B-539490		3	2
96906	MS35489-11	5325-00-291-9366	10	21	80063	SC-B-539517-1		2	30
96906	MS35489-136		4	22	80063	SC-B-539550-1		2	19
96906	MS35493-262	5305-00-015-0964	3	15	80063	SC-8-539583-3		6	4
96906	MS35649-2252	5310-00-997-1888	7	46	80063	SC-B-539586-1		5	1
96906	MS35649-2252	5310-00-997-1888	2	40	80063	SC-B-539586-1		6	12
96906	MS35649-2252	5310-00-997-1888	3	25	80063	SC-B-539586-2		5	12
96906	MS35649-2252	5310-00-997-1888	10	32	80063	SC-B-539608		7	29
96906	MS35649-2312	5310-00-829-9981	2	36	80063	SC-B-539645		10	11
96906	MS35649-2312	5310-00-829-9981	3	27	80063	SC-B-539645-1		10	30
96906	MS35649-262	5310-00-934-9747	3	11	80063	SC-B-539646		10	1
96906	MS35649-262	5310-00-934-9747	10	28	80063	SC-B-539653		10	15
96906	MS35649-282	5310-00-934-9757	7	45	80063	SC-B-539654		10	23
96906	MS35649-282	5310-00-934-9757	4	18	80063	SC-B-539657		10	6
96906	MS35690-9		10	7	80063	SC-B-539792		10	2
96906	MS35691-2	5310-00-834-8736	7	33	80063	SC-B-539873		10	5
96906	MS51922-17	5310-00-087-4652	10	13	80063	SC-B-541556		1	7

## SECTION IV

TM 11-5411-211-24P/EE996-AA-PLL-010/E154 S639/TO 35E41 72-4-1  
 NATIONAL STOCK NUMBER AND PART NUMBER INDEX

NATIONAL STOCK NUMBER		FIG.	ITEM	NATIONAL STOCK NUMBER		FIG.	ITEM
80063	SC-B-543933		1 20	80063	SC-D-681075-38	5	11
80063	SC-B-543934		1 9	80063	SC-D-681226	7	11
80063	SC-B-543937		7 16	80063	SC-D-681278	4	37
80063	SC-B-543939		1 8	80063	SC-D-681400-1	1	16
80063	SC-B-543941		7 24	80063	SC-D-681400-2	1	13
80063	SC-B-627125		7 23	80063	SC-D-681400-3	1	4
80063	SC-B-681042	5970-01-050-4203	10 10	80063	SC-D-681416	1	26
80063	SC-B-681053		6 11	80063	SC-D-681420	7	38
80063	SC-B-681206		10 25	80063	SC-D-883963GR7-4	1	28
80063	SC-B-68449		1 27	80063	SC-D-883964-7	11	1
80063	SC-C-539421	5855-01-072-9865	2 24	80063	SC-D-883964GR7-2	1	29
80063	SC-C-539428	5340-01-169-2882	3 8	80063	SC-D-916230	1	30
80063	SC-C-539440		4 50	80063	SM-C-957512	3	26
80063	SC-C-539449		2 20	81349	SR03N15B1MPO	8	5
80063	SC-C-539457	5340-01-184-6404	4 46	80058	TA-312/T	1	14
80063	SC7C-539529	5340-01-184-6394	4 47	81348	WC00596D7	5935-00-283-4003	4 25
80063	SC-C-539555		2 28	81348	WC375/01-002	5925-01-042-0109	8 8
80063	SC-C-539592		1 37	81348	WC375/01-003	5925-01-111-7562	8 9
80063	SC-C-539648		10 34	81348	WC596/16-1	5935-01-016-3638	4 3
80063	SC-C-539650		10 24	81348	WC596/28-1	5935-01-036-5170	4 8
80063	SC-C-539656		2 43	80063	WC596/41-2	5935-01-024-4028	4 5
80063	SC-C-539665		10 18	81348	WC596/77A		4 29
80063	SC-C-539759-1		7 25	81348	WS896/3-01		4 10
80063	SC-C-539759-1		4 51	09969	099695PA100		7 37
80063	SC-C-539759-5		3 17	95542	2038-8009	5310-00-595-6772	9 6
80063	SC-C-539861		7 12	26916	21C043-0	4540-00-404-9232	10 31
80063	SC-C-539906		10 14	17032	23T21	5930-00-197-4295	10 27
80063	SC-C-629732		1 18	31356	34FHXX11	6625-00-643-3224	8 6
56996	SC-C-6810777		6 13				
80063	SC-C-681078-2		6 14				
80063	SC-C-681078-2		1 39				
80063	SC-C-681318-1		5 2				
80063	SC-C-681318-1		6 3				
80063	SC-C-681318-2		6 1				
80063	SC-C-681398-4		5 10				
80063	SC-C-68191		7 35				
80063	SC-C-916191		1 38				
80063	SC-C-916192		4 35				
80063	SC-C-916200		2 9				
80063	SC-C-916218		2 27				
80063	SC-C-916223		6 8				
80063	SC-C-916237		1 22				
80063	SC-C-916249		4 34				
80063	SC-C-916251		9 4				
80063	SC-C-916263		5 14				
80063	SC-C-916339	5925-01-161-3800	8 11				
80063	SC-C-947703		4 20				
80063	SC-C-947704		4 24				
80063	SC-C-947726		9 12				
80063	SC-C-947747		9 3				
80063	SC-C-947787		1 36				
80063	SC-D-108737		1 25				
80063	SC-D-539460GRI		3 16				
80063	SC-D-539652		10 22				
80063	SC-D-539660		10 19				
80063	SC-D-539901-5		10 20				
80063	SC-D-577980		2 41				
80063	SC-D-578131		1 10				
80063	SC-D-608622	5340-01-094-5434	3 3				
80063	SC-D-681033		4 41				

By Order of the Secretaries of the Army, the Navy and the Air Force:

Official:

DONALD J. DELANDRO  
*Brigadier General, United States Army*  
*The Adjutant General*

Official:

EARL T. O'LOUGHLIN  
General, USAF, Commander, Air Force  
Logistics Command

Distribution:

To be distributed in accordance with special list.

JOHN A WICKHAM, JR.  
*General, United States Army*  
*Chief of Staff*

G.B. SCHICK, JR.  
*Rear Admiral, United States Navy*  
*Commander, Naval Electronic*  
*Systems Command*

CHARLES A. GABRIEL  
*General, USAF*  
*Chief of Staff*



RECOMMENDED CHANGES TO EQUIPMENT TECHNICAL PUBLICATIONS



THEN... JOT DOWN THE DOPE ABOUT IT ON THIS FORM, CAREFULLY TEAR IT OUT, FOLD IT AND DROP IT IN THE MAIL!

**SOMETHING WRONG WITH THIS PUBLICATION?**

FROM: (PRINT YOUR UNIT'S COMPLETE ADDRESS)

DATE SENT

PUBLICATION NUMBER

PUBLICATION DATE

PUBLICATION TITLE

BE EXACT... PIN-POINT WHERE IT IS

IN THIS SPACE TELL WHAT IS WRONG AND WHAT SHOULD BE DONE ABOUT IT:

PAGE NO.	PARA-GRAPH	FIGURE NO.	TABLE NO.
----------	------------	------------	-----------

TEAR ALONG PERFORATED LINE

PRINTED NAME, GRADE OR TITLE, AND TELEPHONE NUMBER

SIGN HERE:

DA FORM 2028-2 JUL 79

PREVIOUS EDITIONS ARE OBSOLETE.

P.S.—IF YOUR OUTFIT WANTS TO KNOW ABOUT YOUR RECOMMENDATION MAKE A CARBON COPY OF THIS AND GIVE IT TO YOUR HEADQUARTERS.

# THE METRIC SYSTEM AND EQUIVALENTS

## WEIGHT MEASURE

1 Centimeter = 10 Millimeters = 0.01 Meters = 0.3937 Inches  
 1 Meter = 100 Centimeters = 1000 Millimeters = 39.37 Inches  
 1 Kilometer = 1000 Meters = 0.621 Miles

## WEIGHTS

1 Gram = 0.001 Kilograms = 1000 Milligrams = 0.035 Ounces  
 1 Kilogram = 1000 Grams = 2.2 lb.  
 1 Metric Ton = 1000 Kilograms = 1 Megagram = 1.1 Short Tons

## LIQUID MEASURE

1 Milliliter = 0.001 Liters = 0.0338 Fluid Ounces  
 1 Liter = 1000 Milliliters = 33.82 Fluid Ounces

## SQUARE MEASURE

1 Sq. Centimeter = 100 Sq. Millimeters = 0.155 Sq. Inches  
 1 Sq. Meter = 10,000 Sq. Centimeters = 10.76 Sq. Feet  
 1 Sq. Kilometer = 1,000,000 Sq. Meters = 0.386 Sq. Miles

## CUBIC MEASURE

1 Cu. Centimeter = 1000 Cu. Millimeters = 0.06 Cu. Inches  
 1 Cu. Meter = 1,000,000 Cu. Centimeters = 35.31 Cu. Feet

## TEMPERATURE

$5/9(^{\circ}\text{F} - 32) = ^{\circ}\text{C}$   
 212° Fahrenheit is equivalent to 100° Celsius  
 90° Fahrenheit is equivalent to 32.2° Celsius  
 32° Fahrenheit is equivalent to 0° Celsius  
 $9/5^{\circ}\text{C} + 32 = ^{\circ}\text{F}$

## APPROXIMATE CONVERSION FACTORS

TO CHANGE	TO	MULTIPLY BY
Inches	Centimeters	2.540
Feet	Meters	0.305
Yards	Meters	0.914
Miles	Kilometers	1.609
Square Inches	Square Centimeters	6.451
Square Feet	Square Meters	0.093
Square Yards	Square Meters	0.836
Square Miles	Square Kilometers	2.590
Acres	Square Hectometers	0.405
Cubic Feet	Cubic Meters	0.028
Cubic Yards	Cubic Meters	0.765
Fluid Ounces	Milliliters	29.573
its	Liters	0.473
arts	Liters	0.946
allons	Liters	3.785
Ounces	Grams	28.349
Pounds	Kilograms	0.454
Short Tons	Metric Tons	0.907
Pound-Feet	Newton-Meters	1.356
Pounds per Square Inch	Kilopascals	6.895
Miles per Gallon	Kilometers per Liter	0.425
Miles per Hour	Kilometers per Hour	1.609

TO CHANGE	TO	MULTIPLY BY
Centimeters	Inches	0.394
Meters	Feet	3.280
Meters	Yards	1.094
Kilometers	Miles	0.621
Square Centimeters	Square Inches	0.155
Square Meters	Square Feet	10.764
Square Meters	Square Yards	1.196
Square Kilometers	Square Miles	0.386
Square Hectometers	Acres	2.471
Cubic Meters	Cubic Feet	35.315
Cubic Meters	Cubic Yards	1.308
Milliliters	Fluid Ounces	0.034
Liters	Pints	2.113
Liters	Quarts	1.057
ers	Gallons	0.264
ms	Ounces	0.035
ograms	Pounds	2.205
Metric Tons	Short Tons	1.102
Newton-Meters	Pounds-Feet	0.738
Kilopascals	Pounds per Square Inch	0.145
ometers per Liter	Miles per Gallon	2.354
ometers per Hour	Miles per Hour	0.621



**PIN: 055892-000**